



www.altanatubes.com

Manual de montagem do KIT 5E1

Partes do seu kit

Parabéns por adquirir o KIT 5E1 da Altana Tubes. Com ele você terá não apenas prazer de montar o seu próprio amplificador, como a certeza de ter um som vintage de um dos circuitos mais consagrados.

Seu KIT deve contar as seguintes peças:

- 2 resistores 1K5 1W (marrom, verde, preto, marrom, marrom)
- 2 resistores 68K 1W (azul, cinza, preto, vermelho, marrom)
- 2 resistores 100K 1W (marrom, preto, preto, laranja, marrom)
- 2 resistores 22K 1W (vermelho, vermelho, preto, vermelho, marrom)
- 1 resistor 10K 2W (marrom, preto, preto, vermelho, marrom)
- 1 resistor 1M 1W (marrom, preto, preto, amarelo, marrom)
- 1 resistor 220K 1W (vermelho, vermelho, preto, laranja, marrom)
- 1 resistor 470R 10W (corpo de louça)
- 2 capacitores eletrolíticos 25uF 25V
- 2 capacitores eletrolíticos 8uf 450V
- 1 capacitor eletrolítico 22uF 450V
- 1 válvula 6V6
- 1 válvula 12AX7
- 1 válvula 5Y3 ou 5AR4 (na versão valvulada)
- 2 diodos BYV26EV (na versão estado sólido)
- 1 transformador de força
- 1 transformador de saída
- 1 chassis em aço inox
- 1 potenciômetro
- 1 knob
- 1 placa com torretes
- 2 soquetes octais
- 1 soquete miniatura 9 pinos com blindagem
- Cordão de força

- Fios
- 3 conectores P10
- 2 cliques para válvula octal
- Fusível
- Porta fusível
- Lâmpada piloto
-

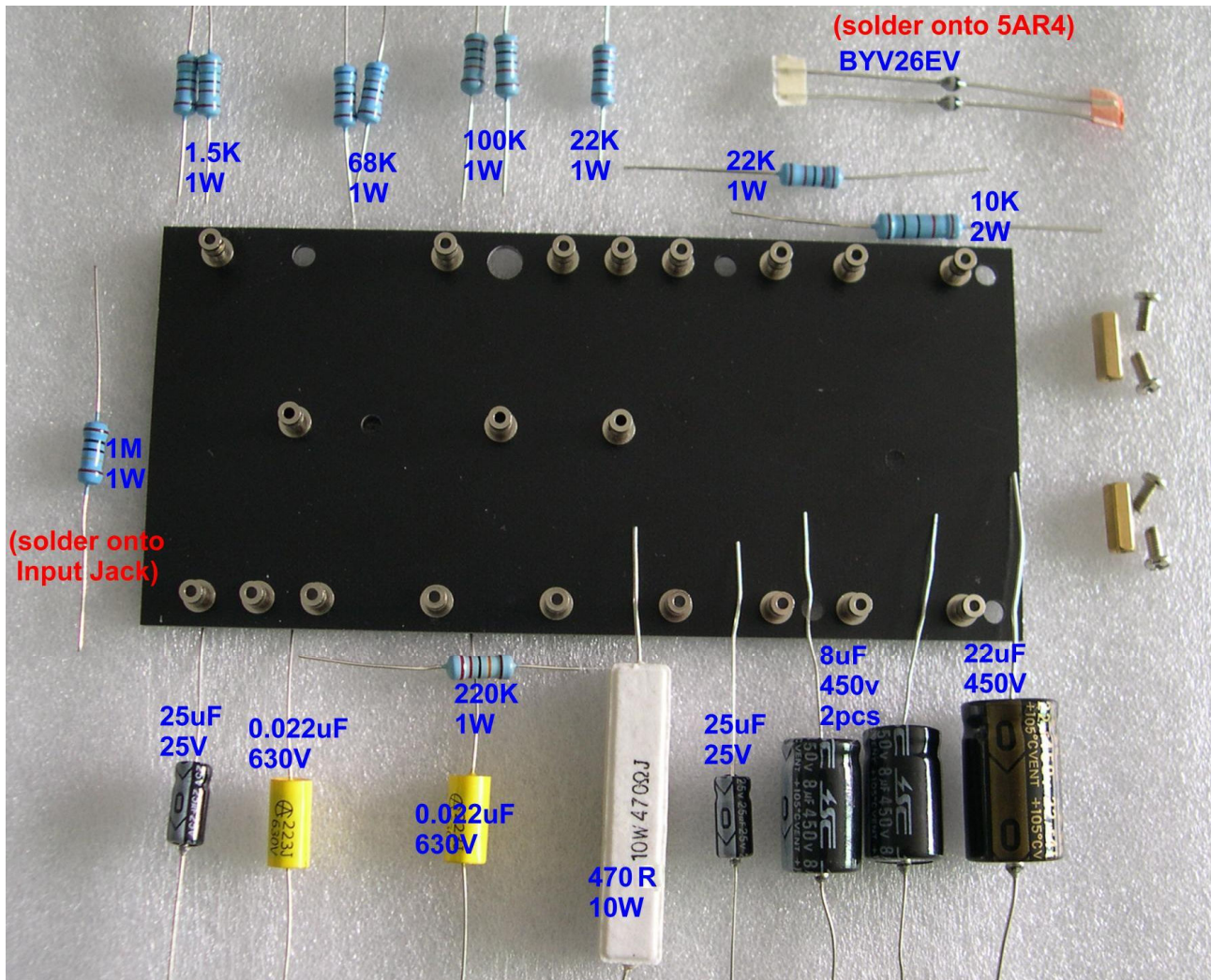

a. board assembly:

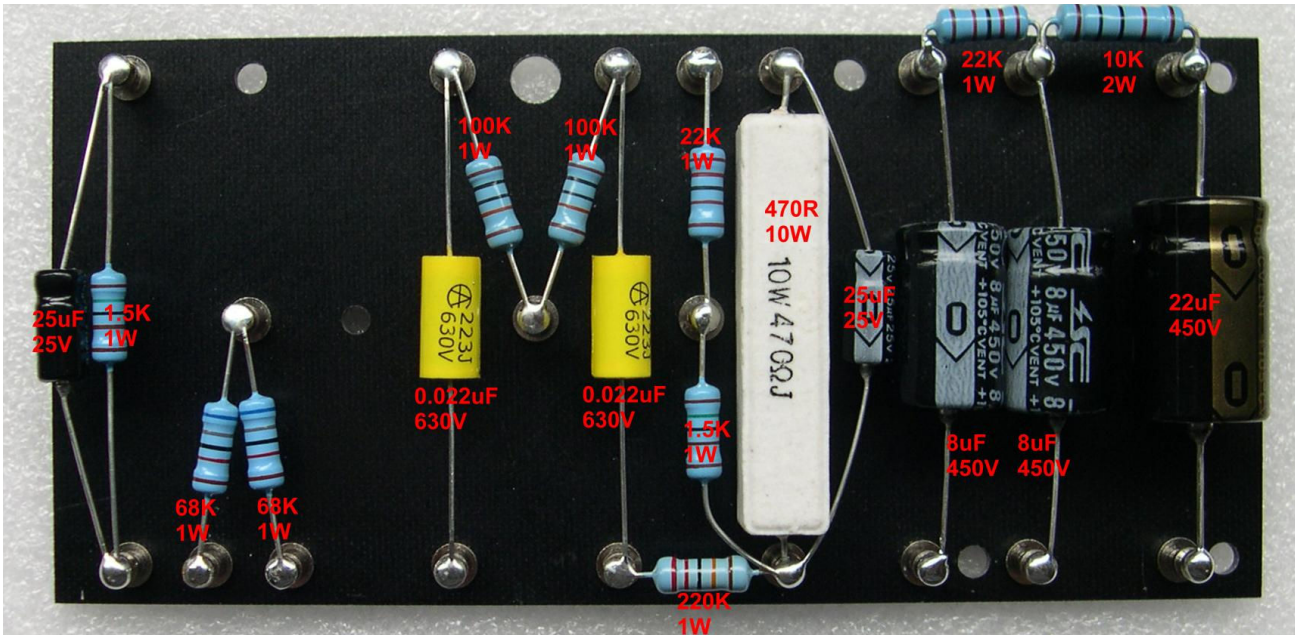

b. board wiring:

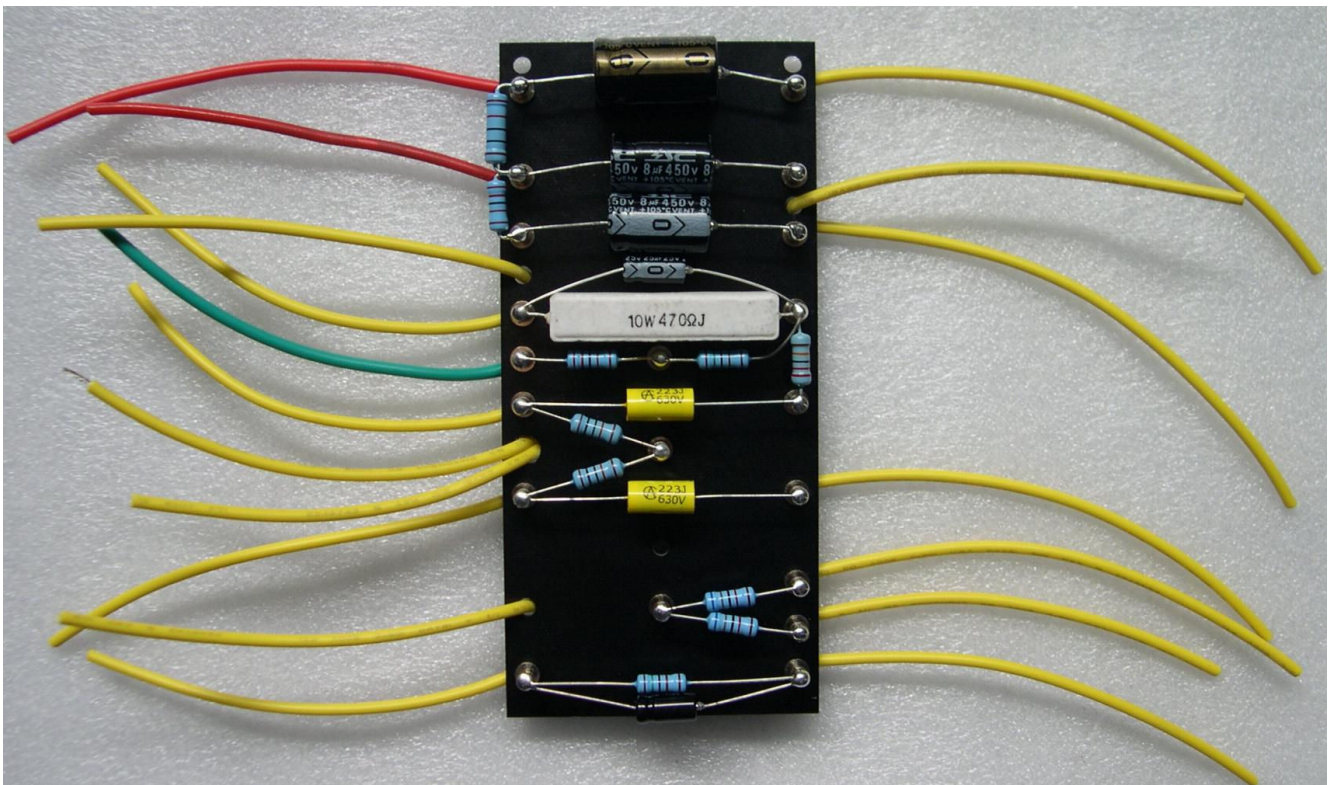

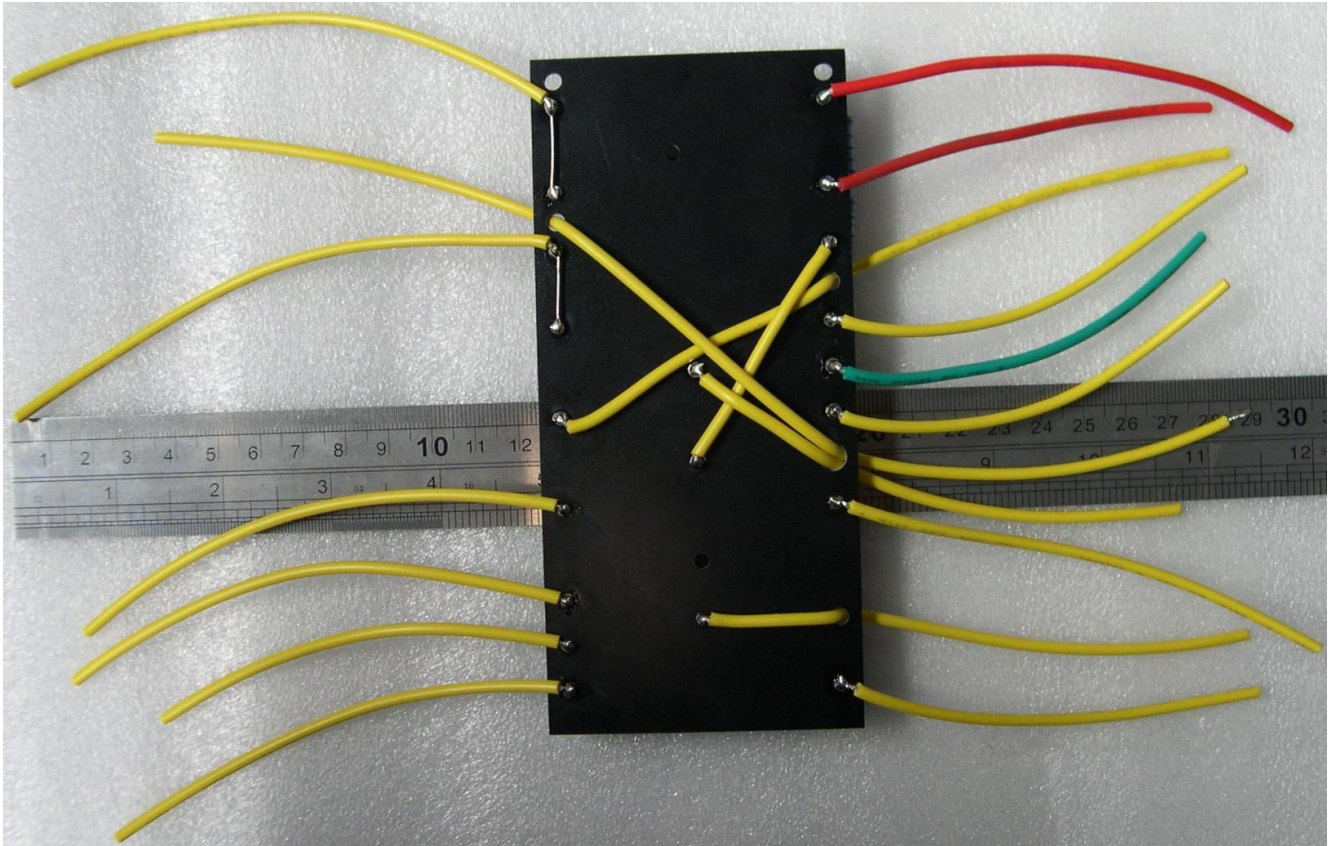

1. **Montagem do chassis** - (Recomendamos o uso de luvas ao manusear o chassis para evitar marcas de impressão digital)



Fiação dos transformadores:

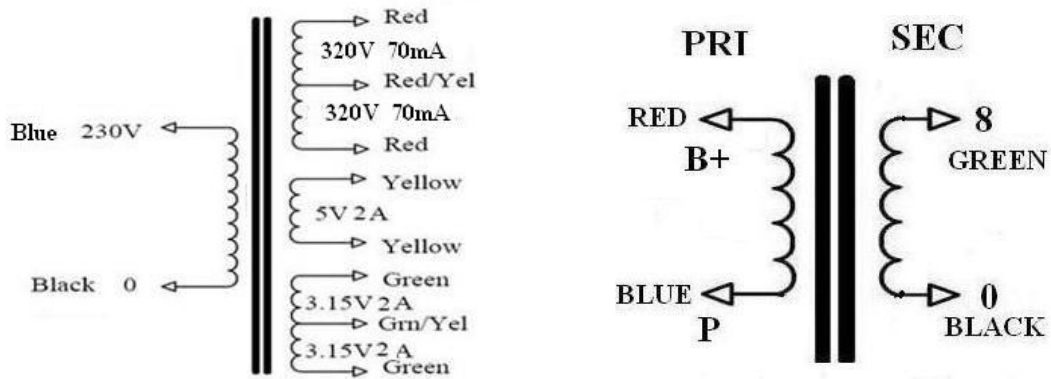

PT Sch (above)

OT Sch (above)

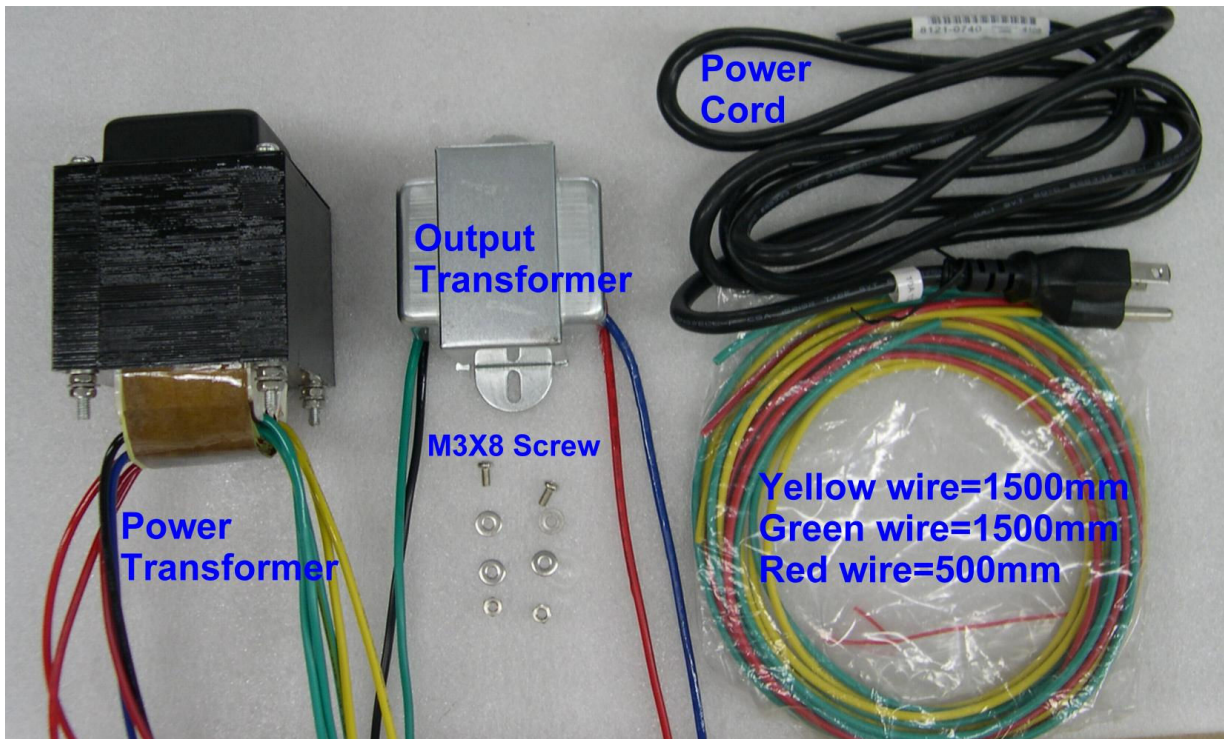

- a. Mount one 9pin preamp tube sockets, one output jack and two octal tube socket on the back panel of the chassis;
- b. And mount 2 hex standoffs as well as 2 rubber grummets on the bottom of chassis;
(see below 2 pics for details)

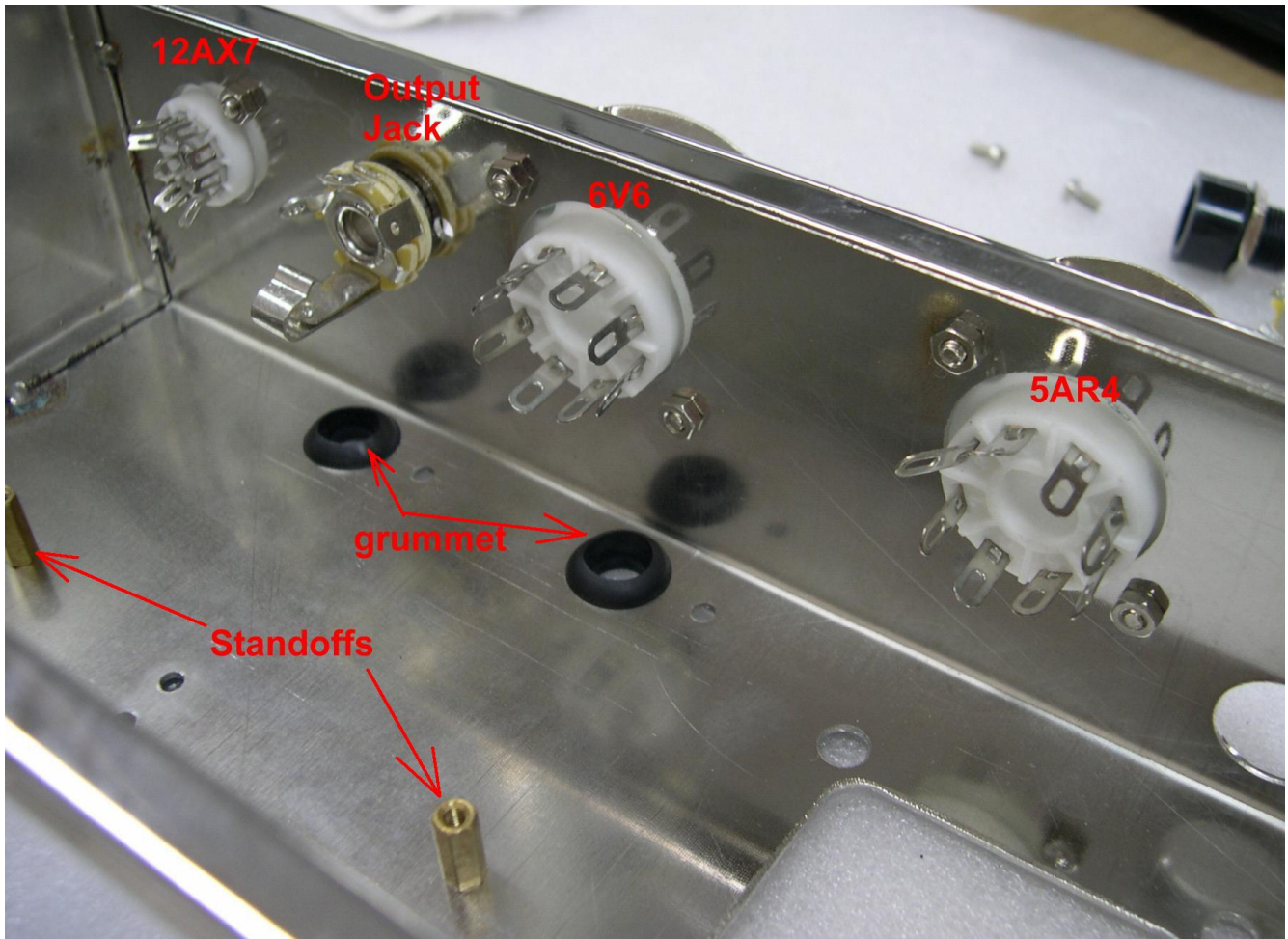

Please note tube socket direction.

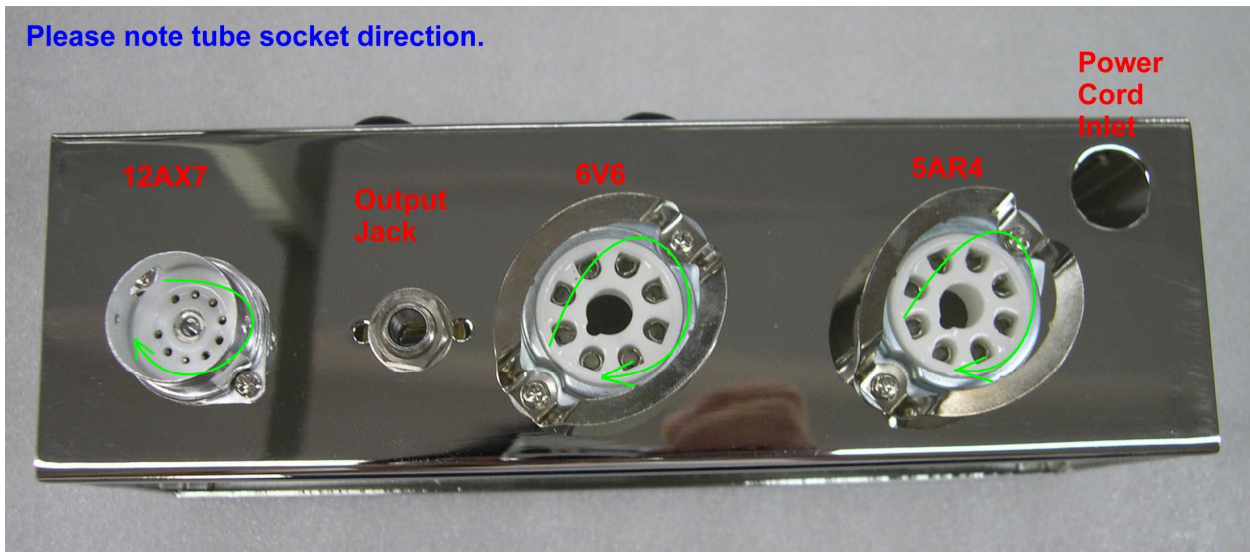

c. Filament wiring- 12ax7 Pin4&5 to 6V6 Pin2; 12ax7 Pin9 to 6V6 Pin7; (see below pics)

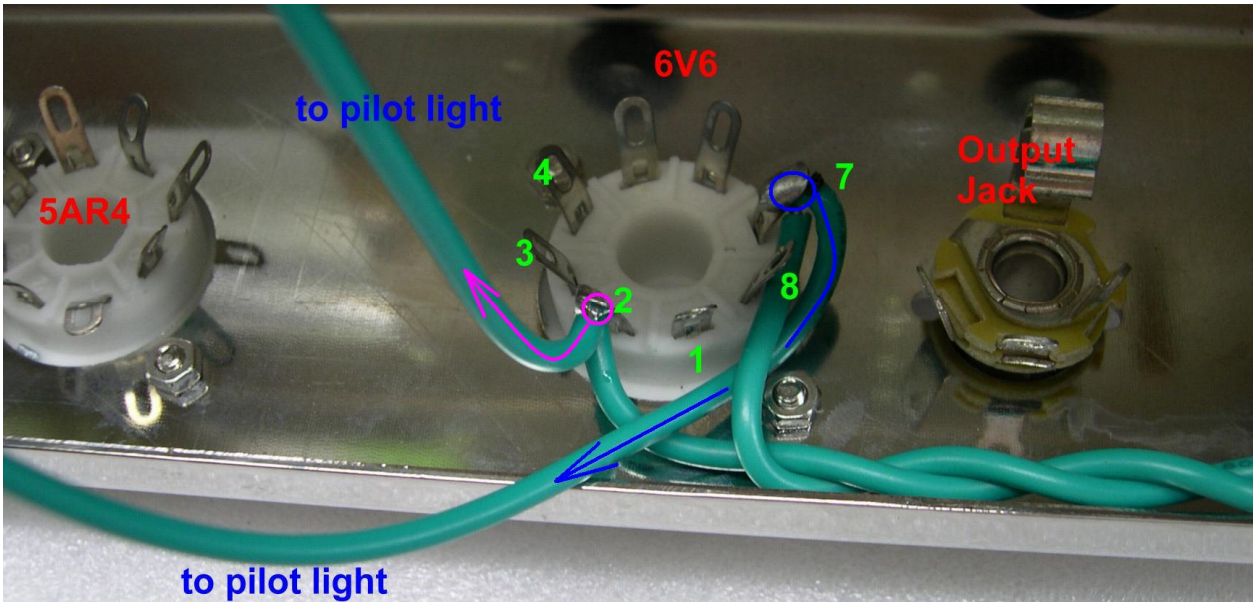
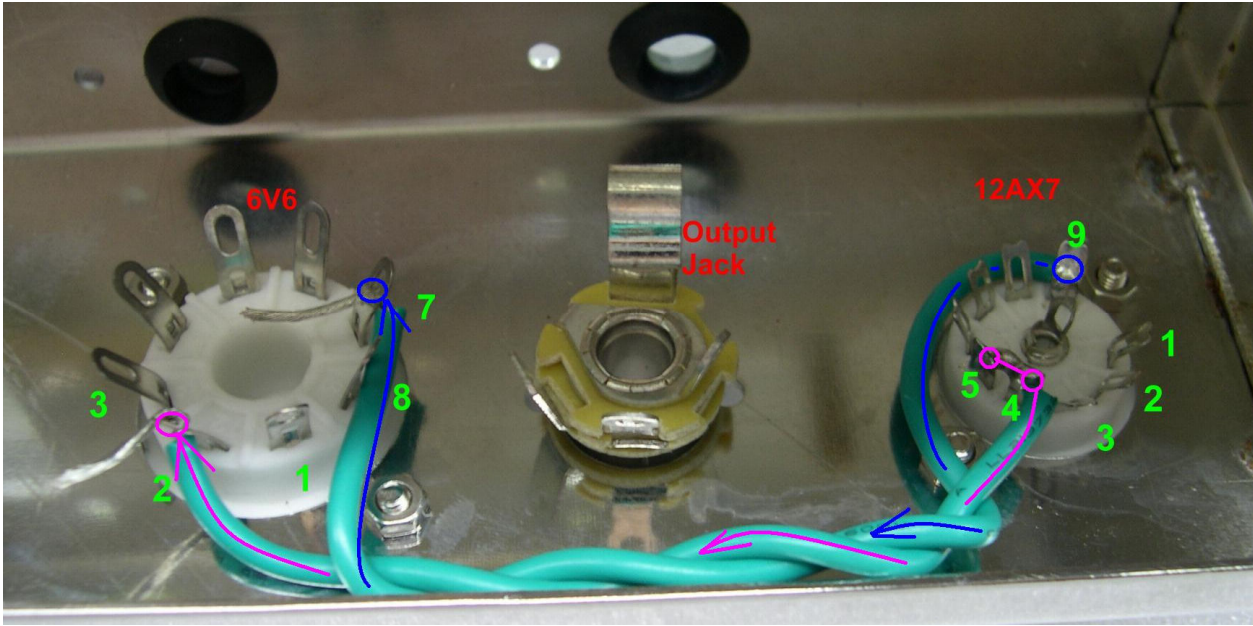

d. Output transformer mount- (see pics below)

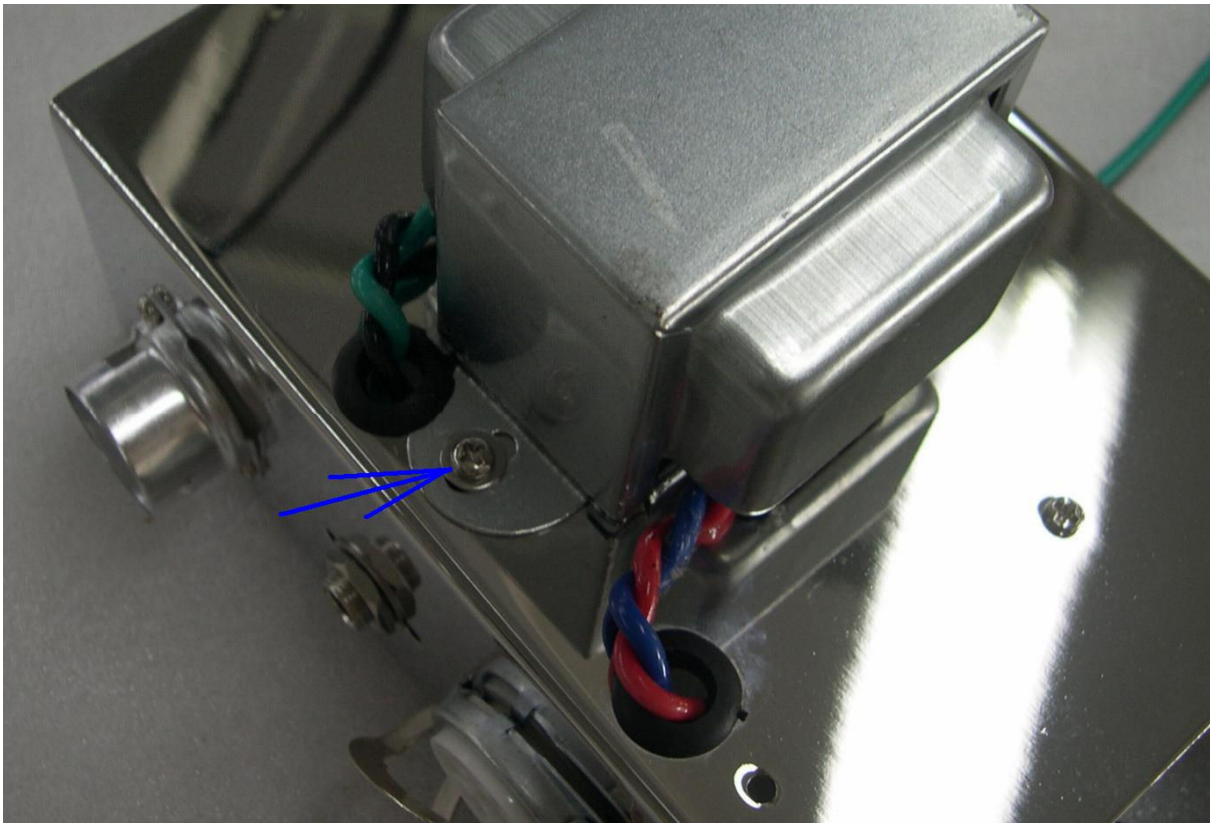
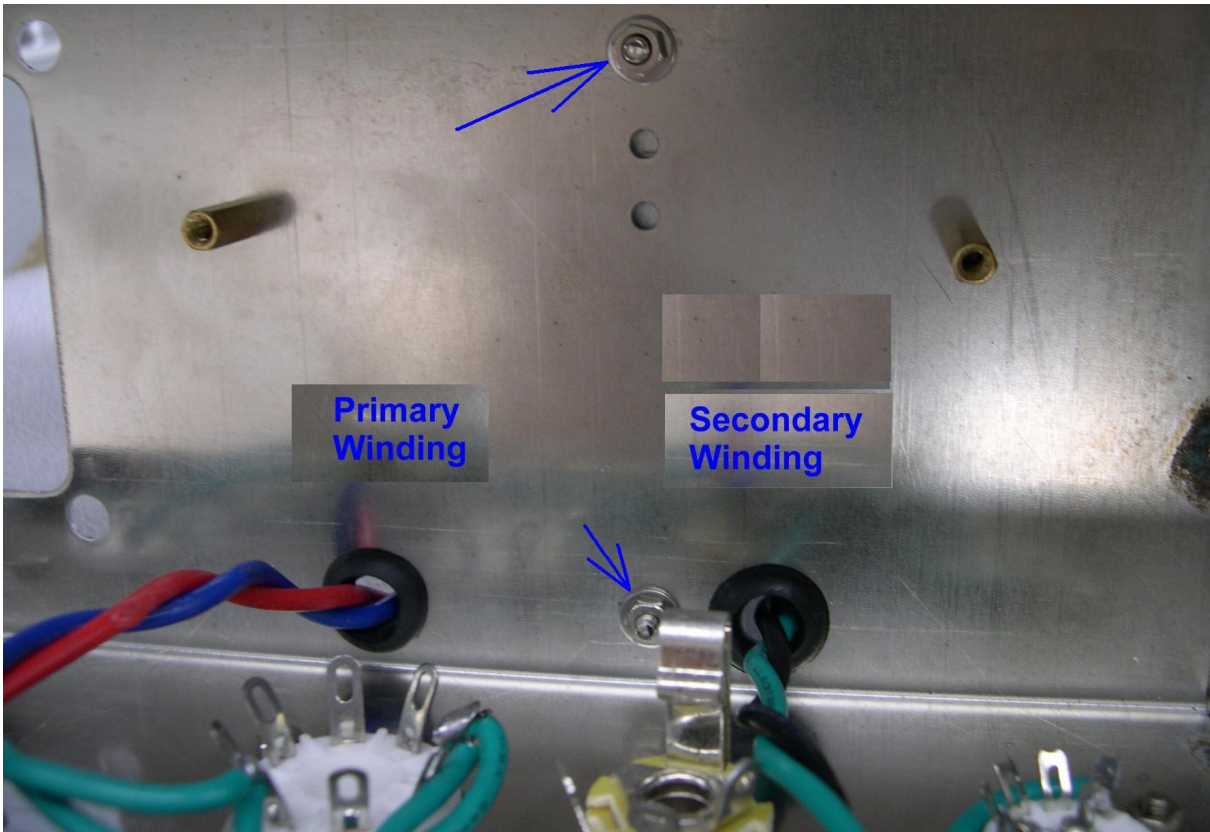

e. Output transformer wiring-

-connect black wire from OT secondary to Pin1 of output jack;

-connect blue wire from OT primary to Pin3 of 6V6 tube socket; (see pic below)

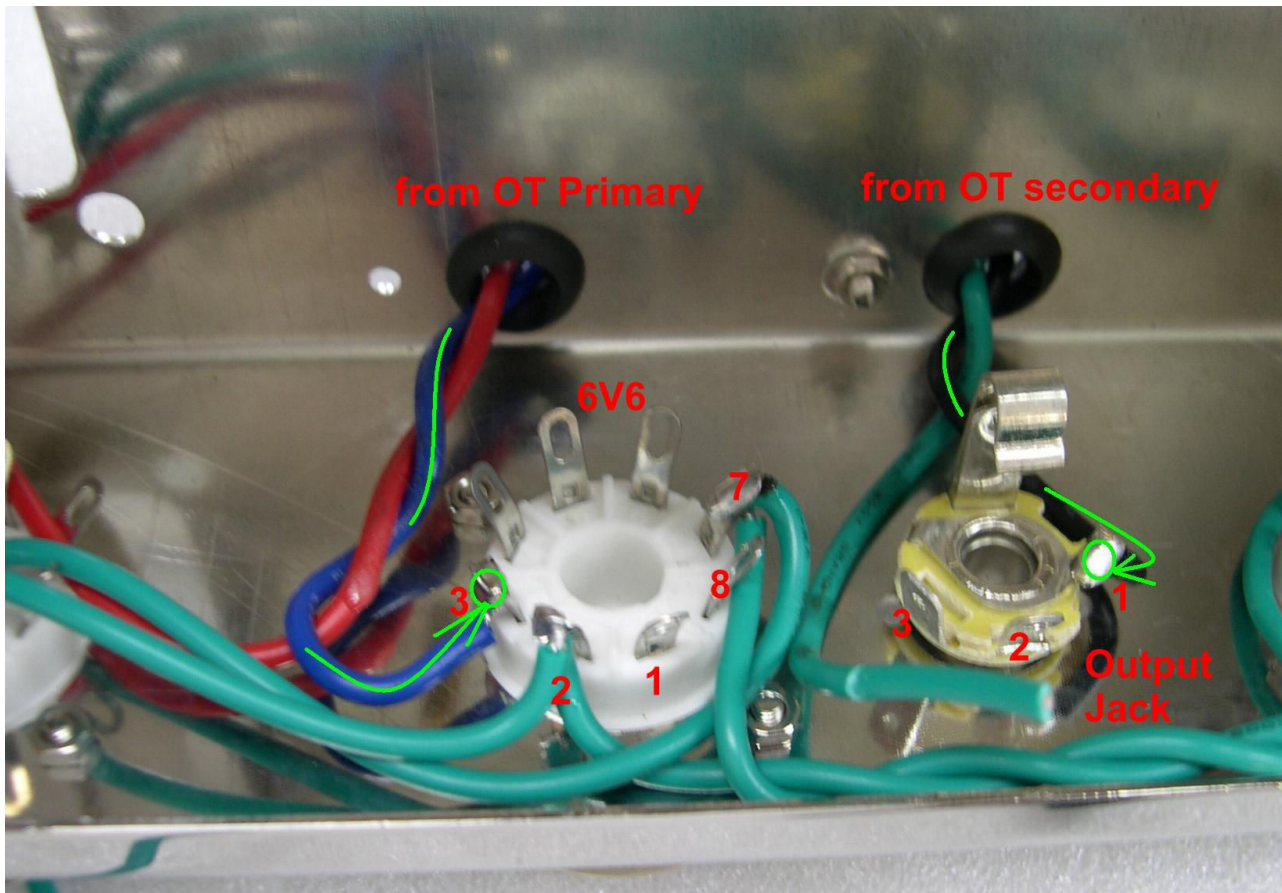

f. Turret board mount- screw the board in place, (see below pic)

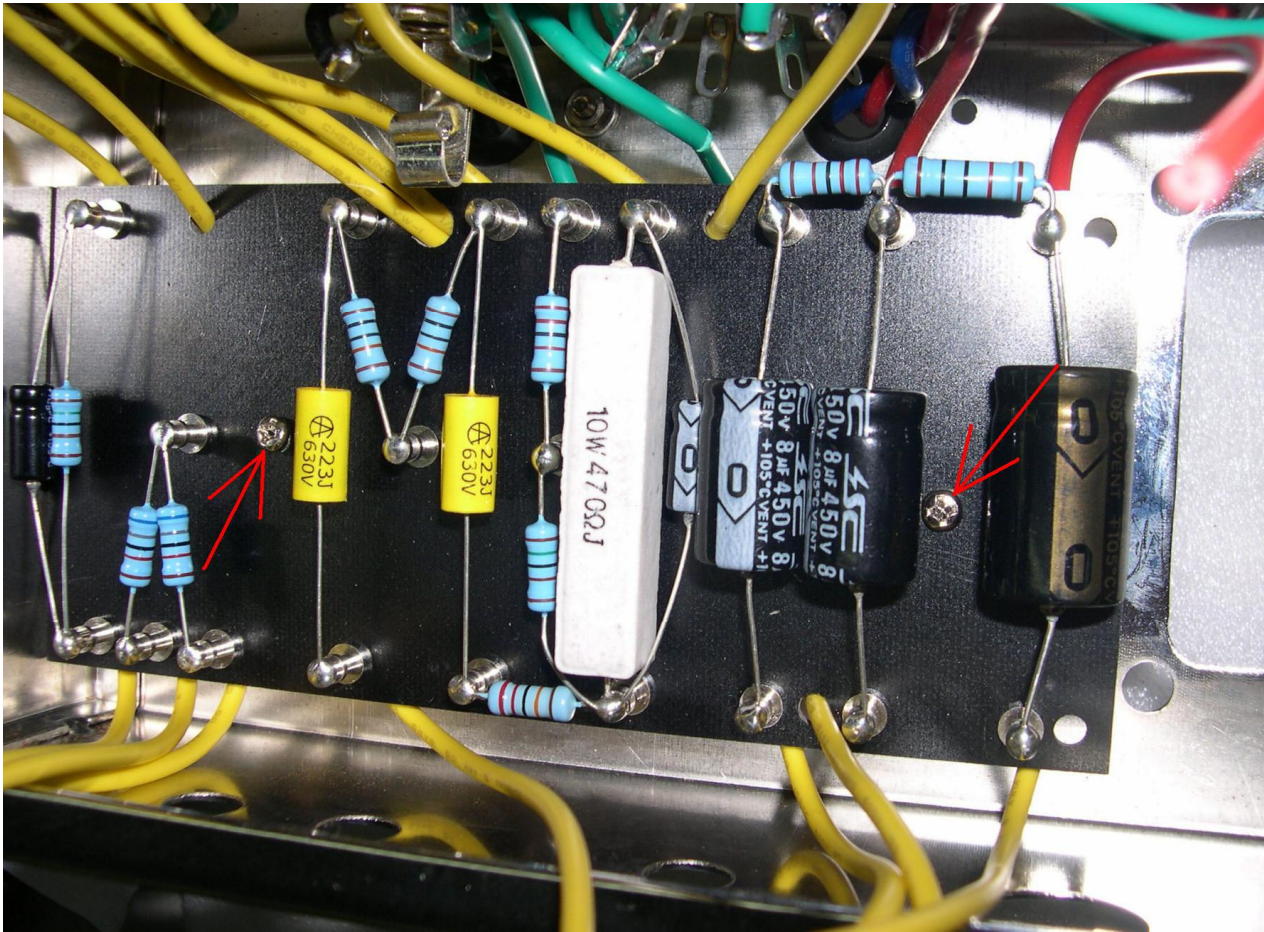

g. Output transformer wiring2- (see below pic)

-Twist Green wire from OT secondary and Green wire from the turret board Pin7 together and connect them to Pin3 of output jack;

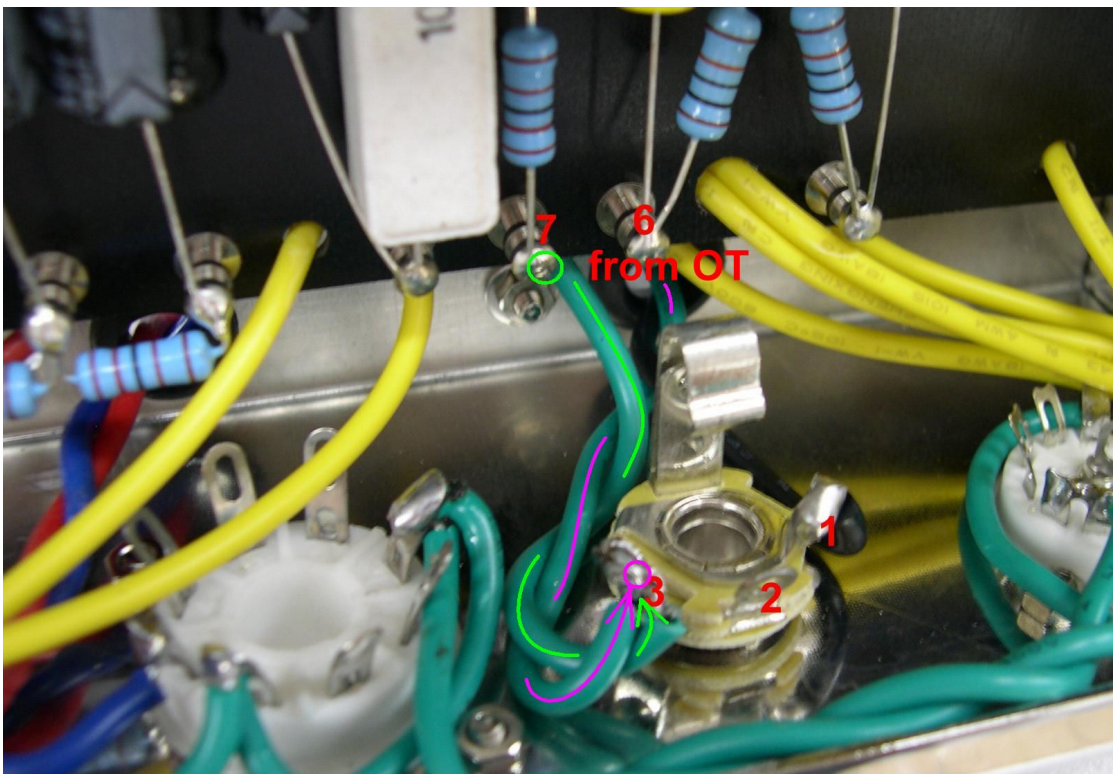

h. 12AX7 wiring- Board Pin1 to 12ax7 Pin3; Board Pin2 to 12ax7 Pin2; Board Pin3 to 12ax7 Pin3;
(see below pic)

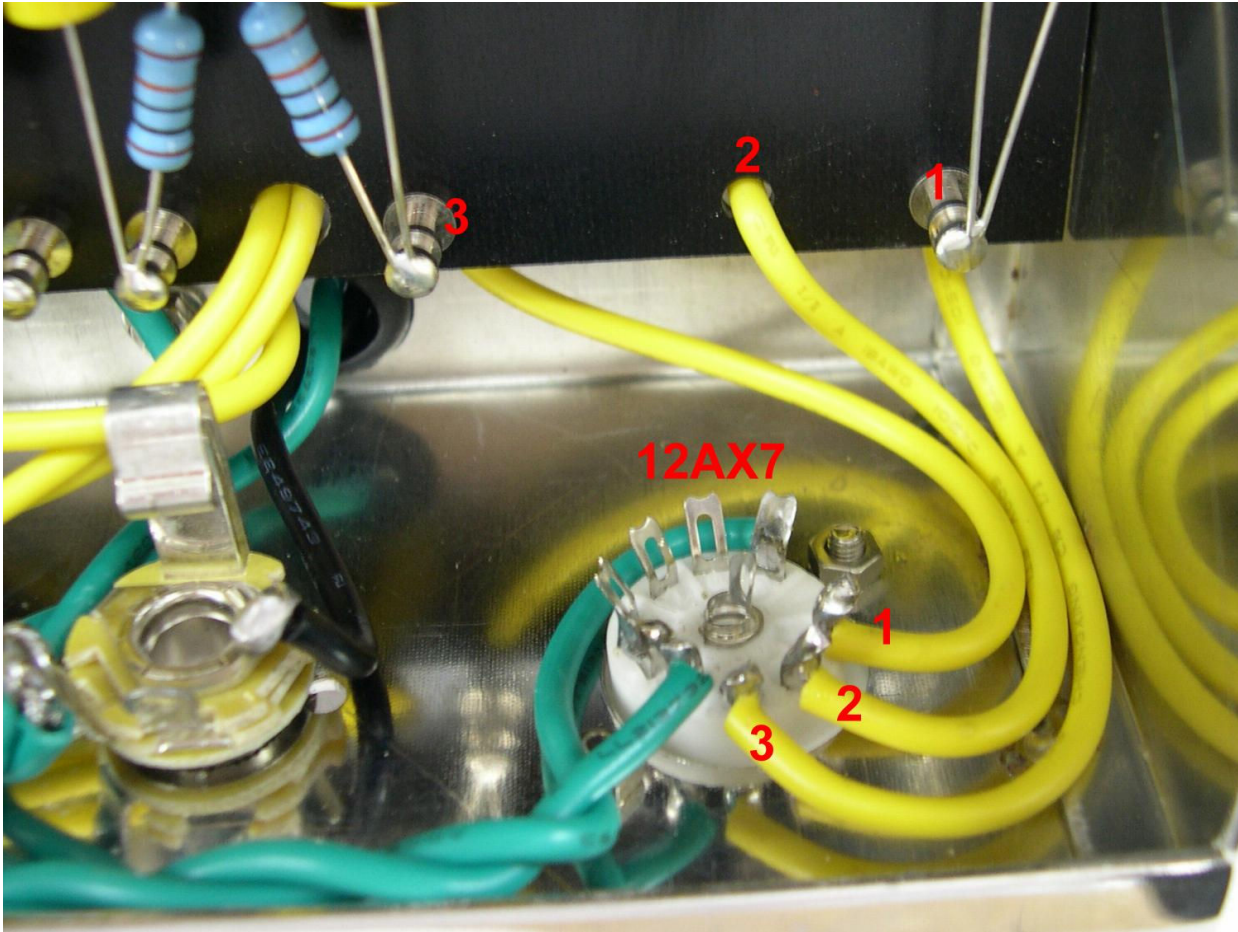

12AX7 wiring- Board Pin4 to 12ax7 Pin8; Board Pin5(from pot) to 12ax7 Pin7; Board Pin6 to 12ax7 Pin6;

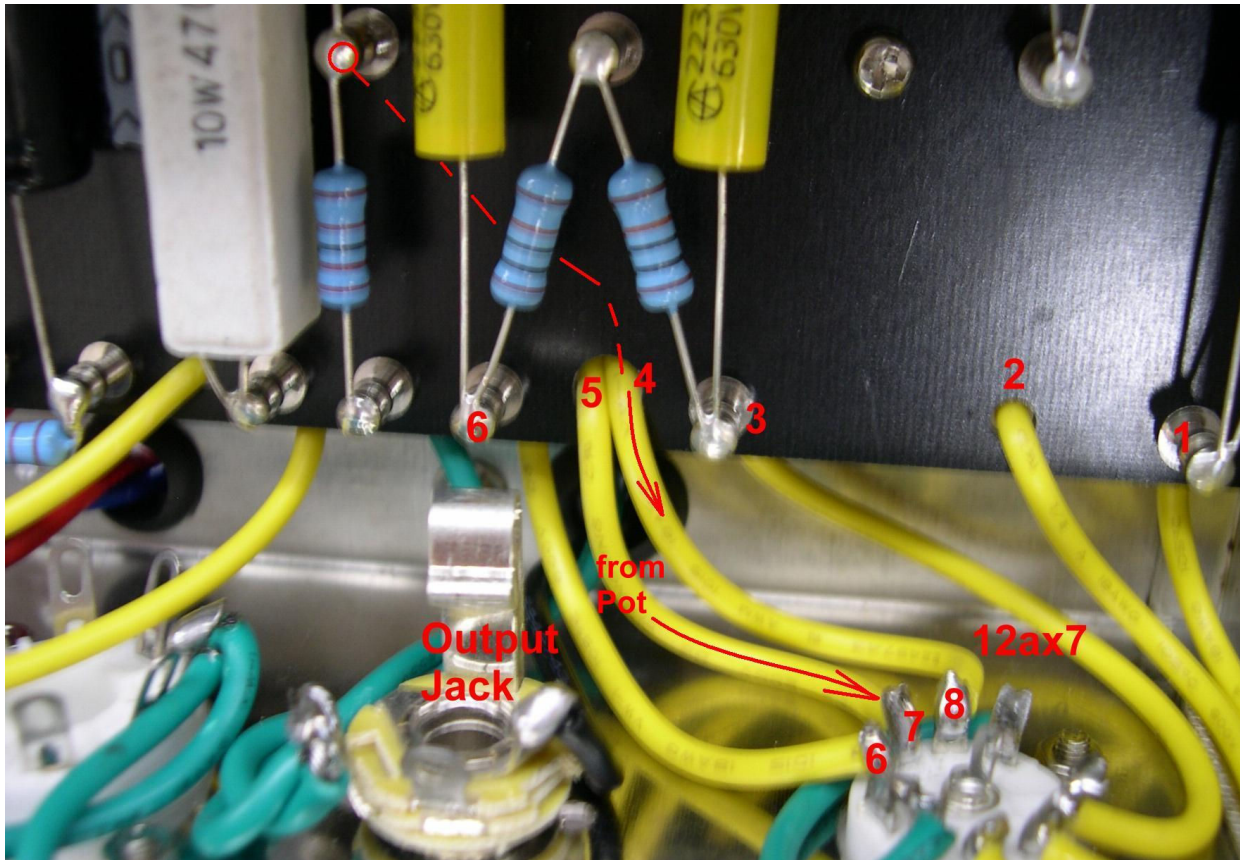

i. 6V6 power tube wiring- connect the yellow wire that mark point9 as below from the turret board to 6V6 tube socket Pin5; (see below pic)

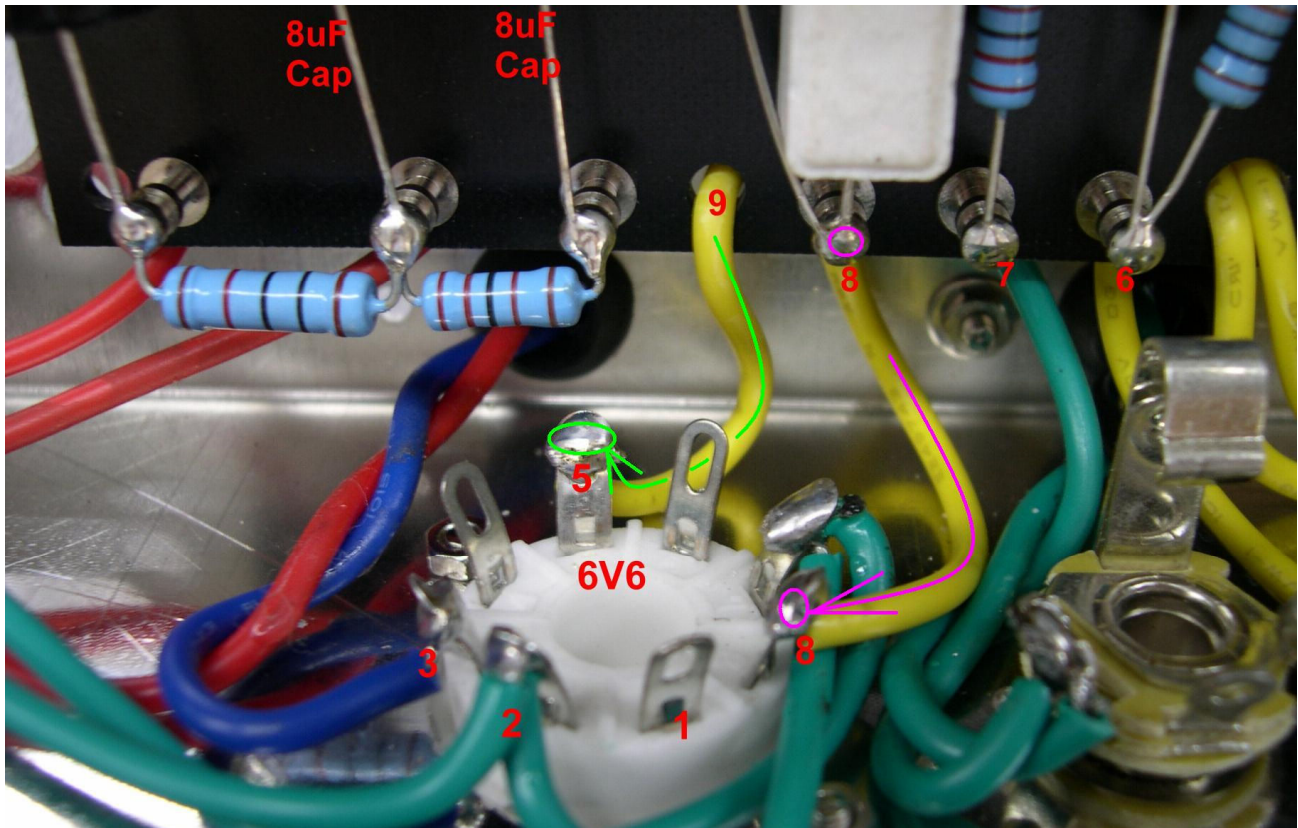

Connect Point11 from the turret board to 6V6 tube socket Pin4; (see below pic)

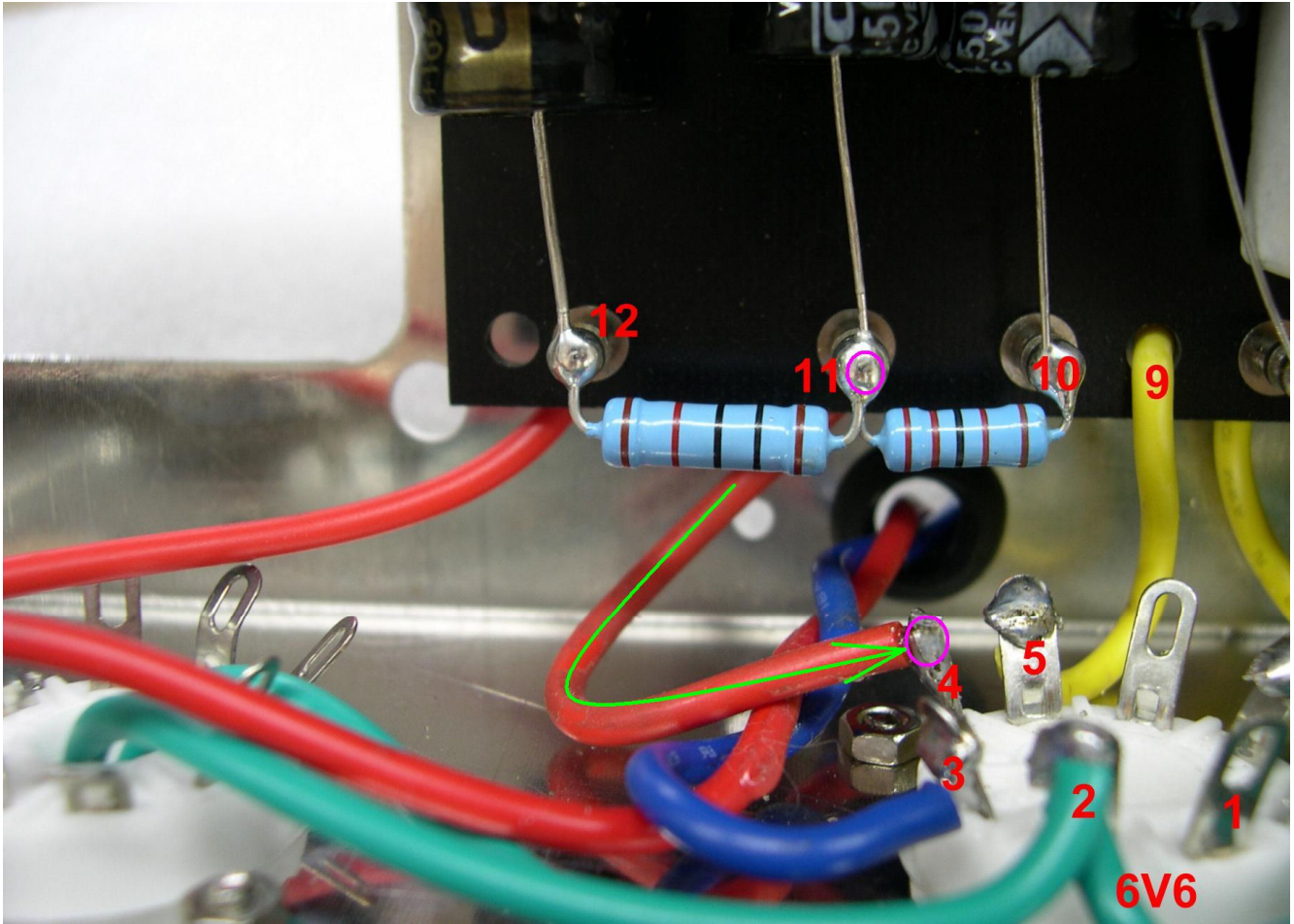

j. Now, you need to mount these components to the front panel of the chassis, see below pic:

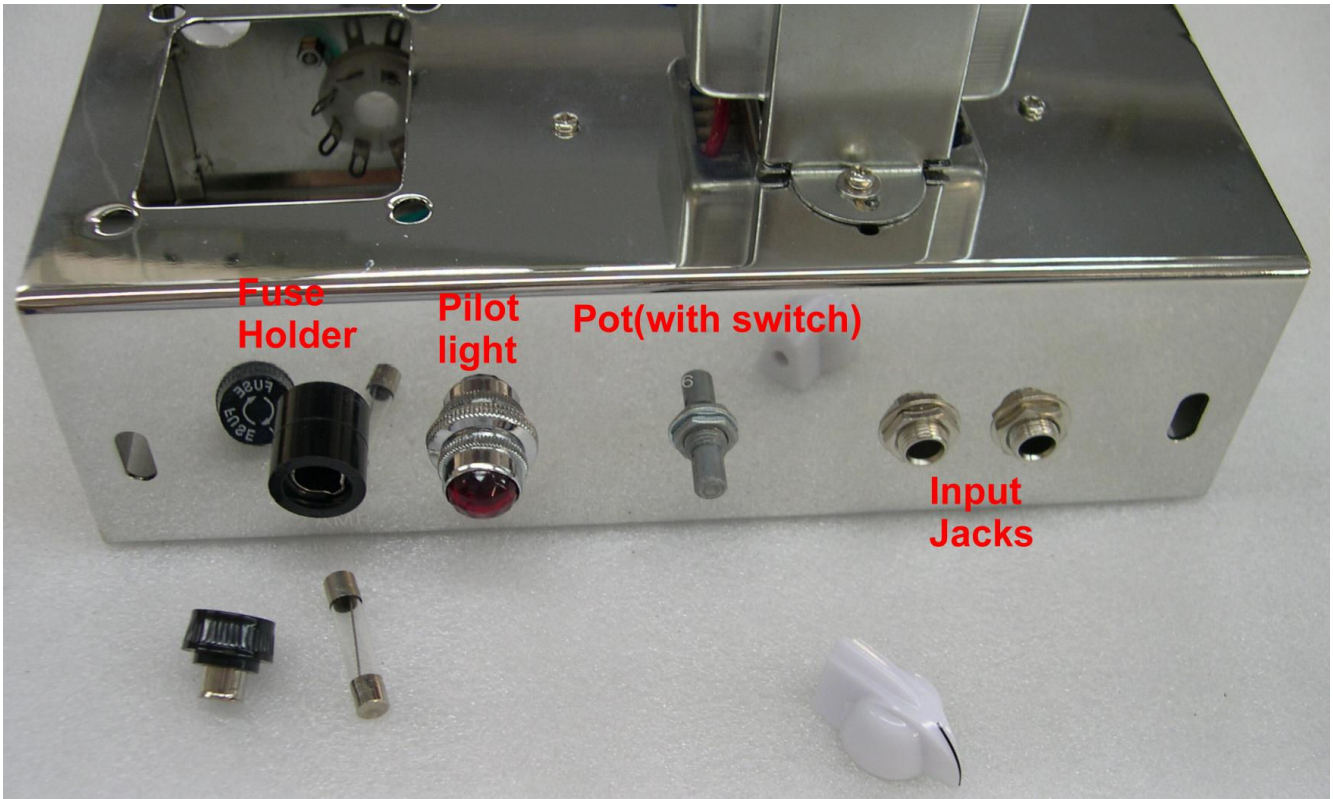

k. Input Jacks wiring- connect point1 on the turret board to Pin3 of Jack1; and connect point2 on the turret board to Pin1 of Jack1; (see below pic)

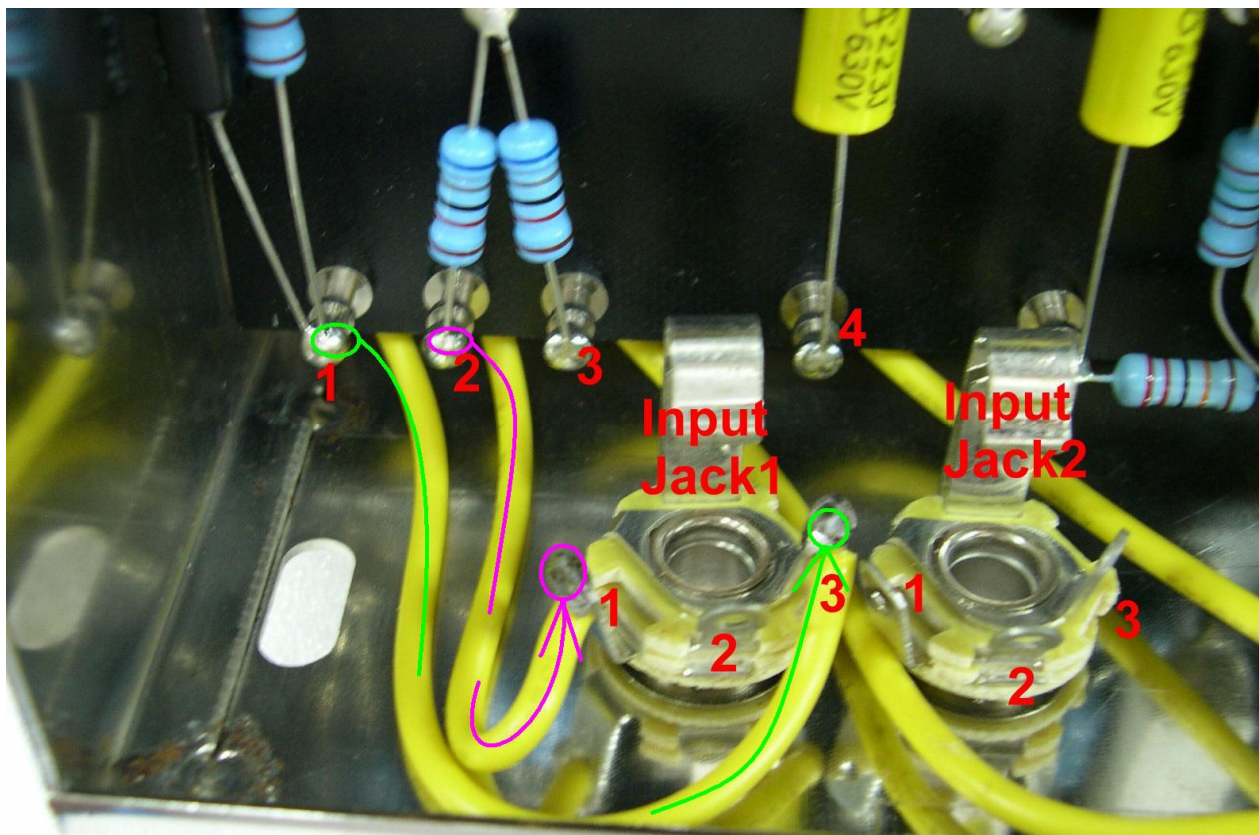

Connect Pin3 on the turret board to Pin1 of Jack1; Connect Pin2 of Jack1 to Pin1 of Jack2; Connect a 1Mohms resistor across Pin1 of Jack2 to Pin3 of Jack2; Connect Pin2 of Jack2 to Pin3 of Jack2; Connect Pin7 on the turret board to Pin3 of Jack2; (see below pic)

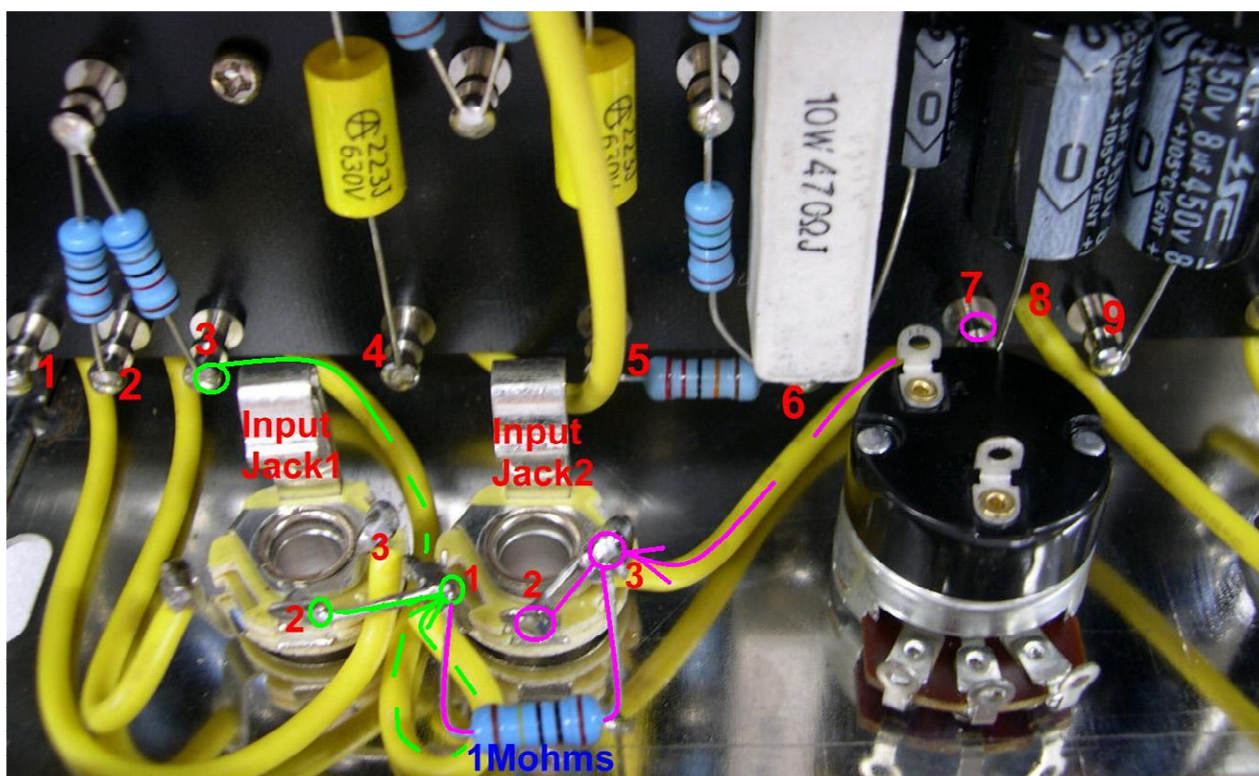

Potentiometer wiring- Connect Point4 on the turret board to Pin1 of Potentiometer; Connect Point8 on the turret board to Pin2 of Potentiometer; Connect Pin3 of Input Jack2 to Pin3 of Potentiometer. (see below pic)

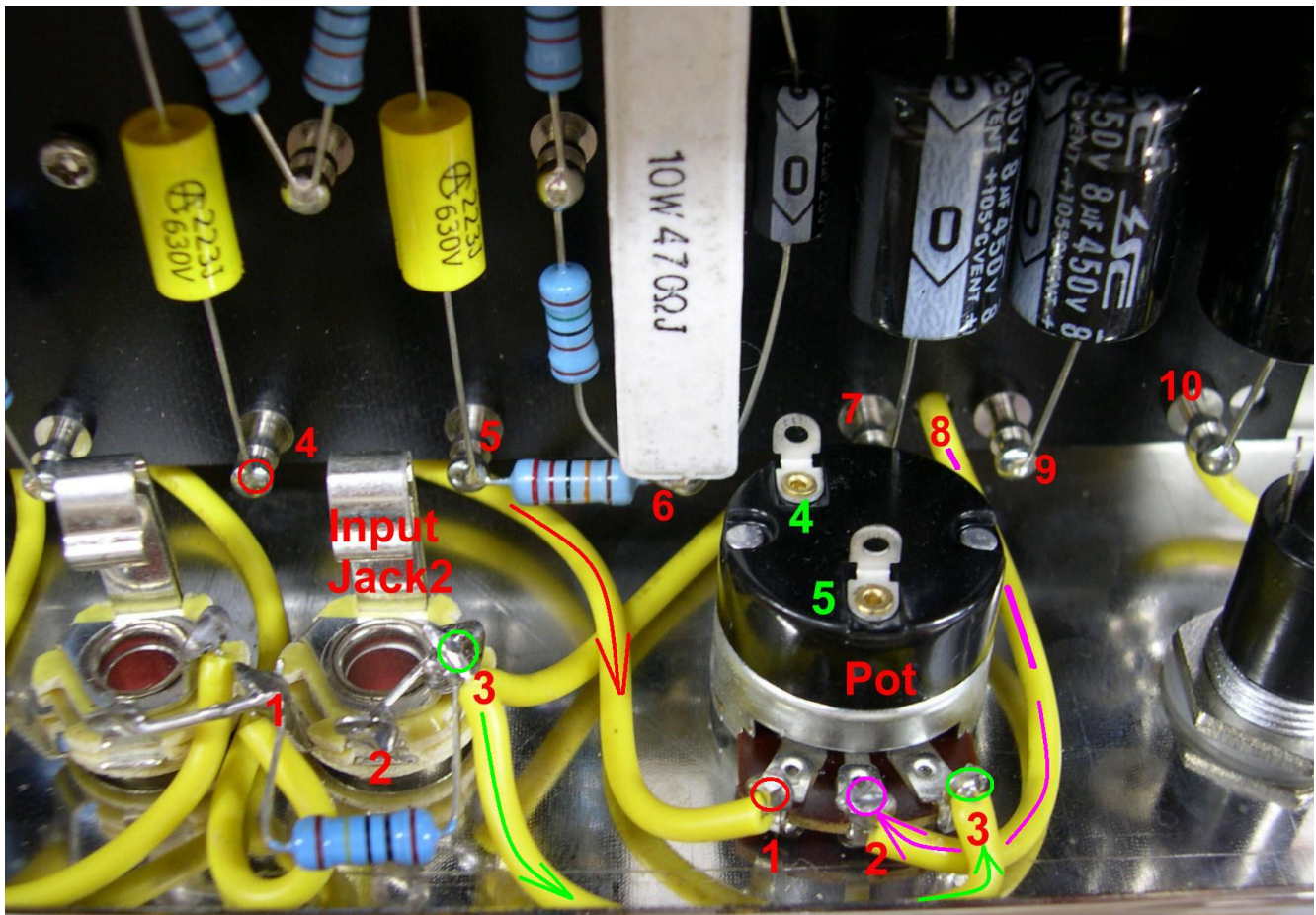

I. Power transformer mount – (see below pics)

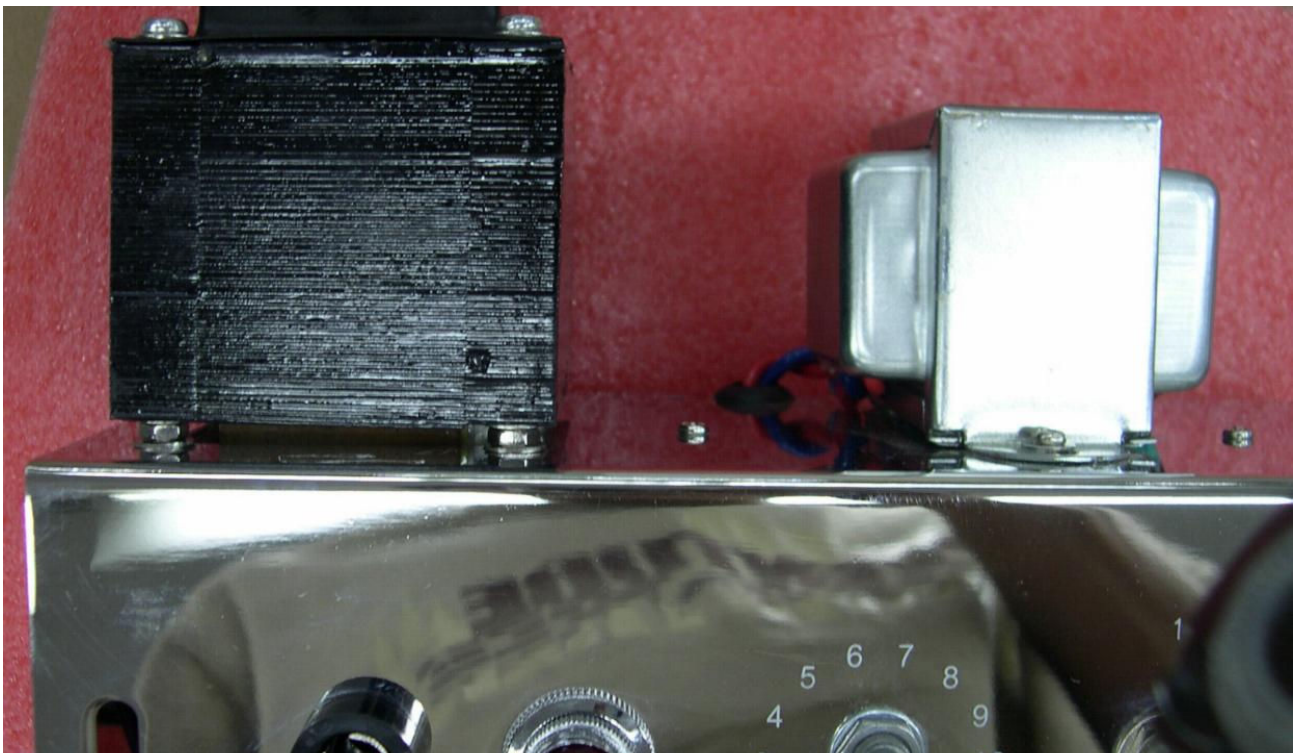
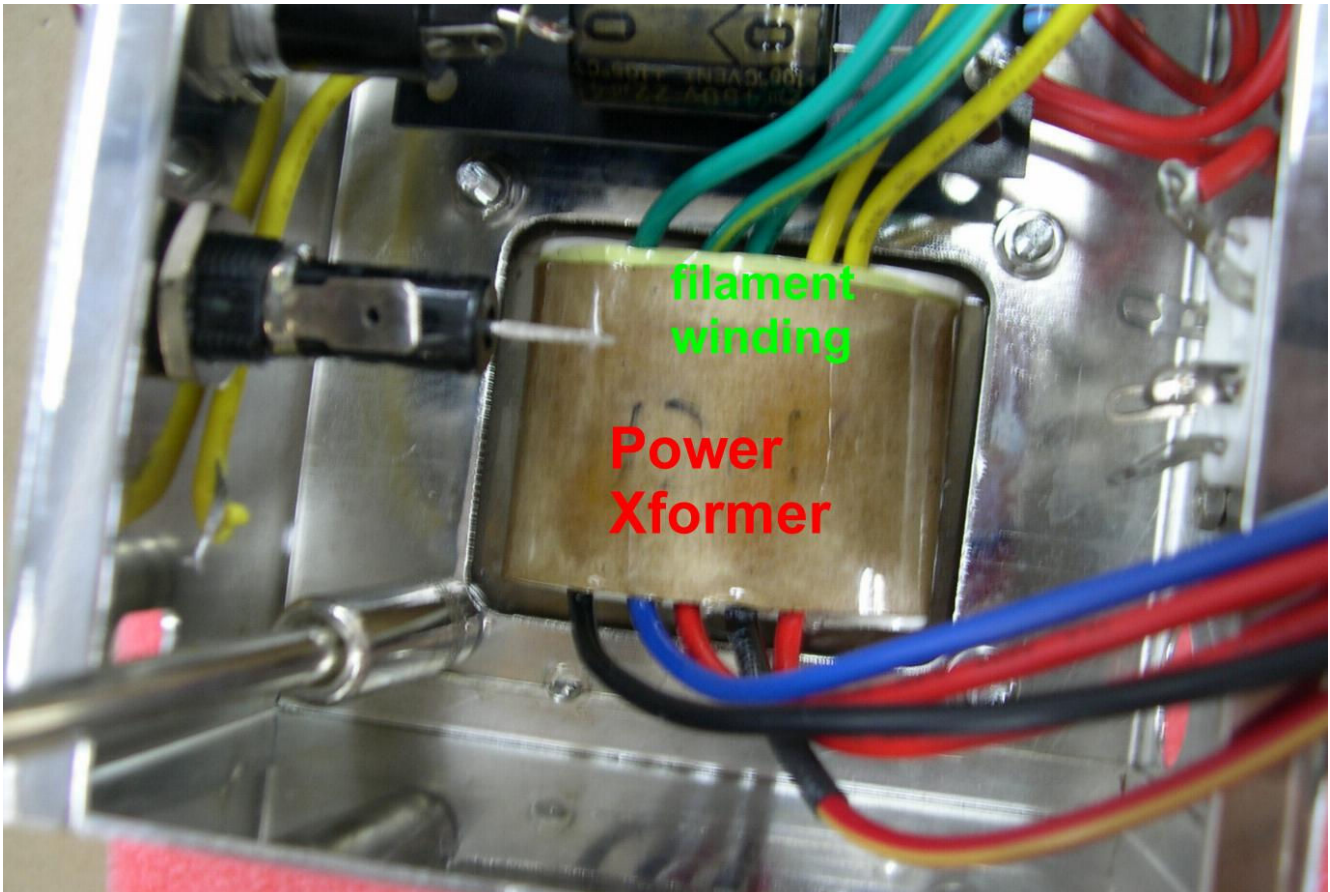

m. Filament wire from PT to Indicator and 6V6 tube- combine one green wire from PT with one green wire from 6V6 tube together and then solder them to Indicator Pin1; (see below Red color arrow)

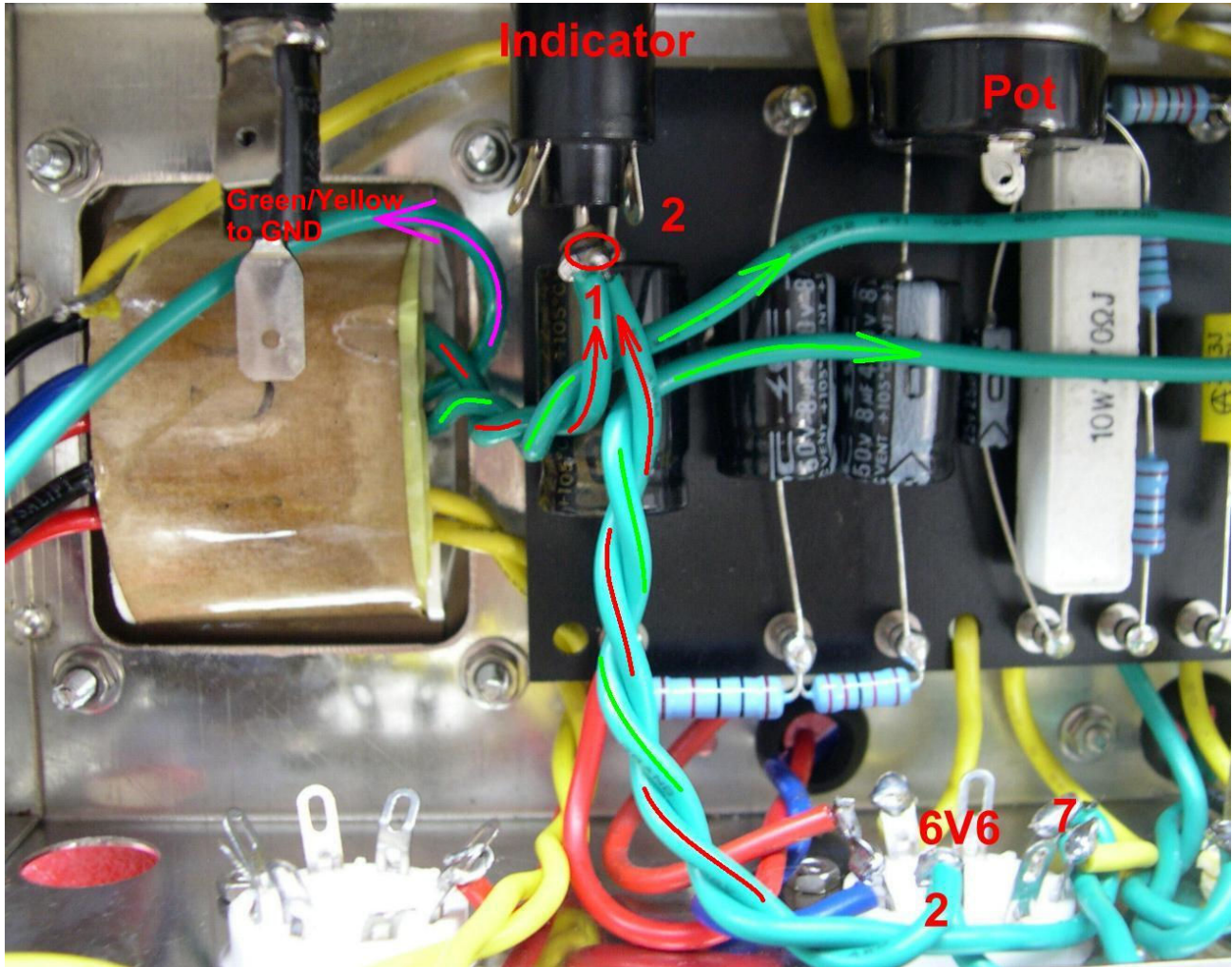

Combine the other green wire from PT with the other green wire from 6V6 tube together and solder them to Indicator Pin2; (see below Red color arrow)

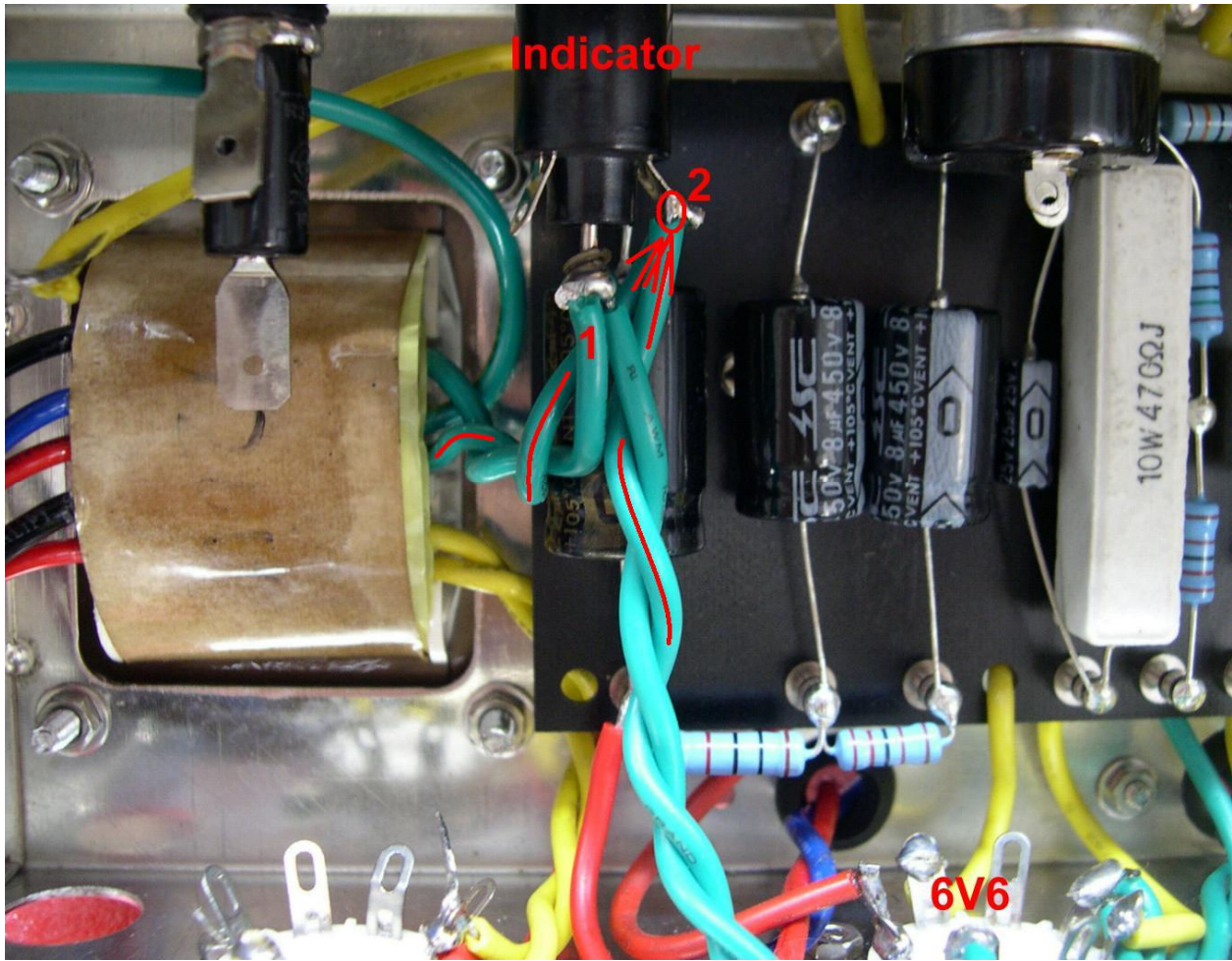

n. 5AR4 rectifier tube wirings- Connect Point12 on Turret board to Pin8 of 5AR4 tube socket, see below:

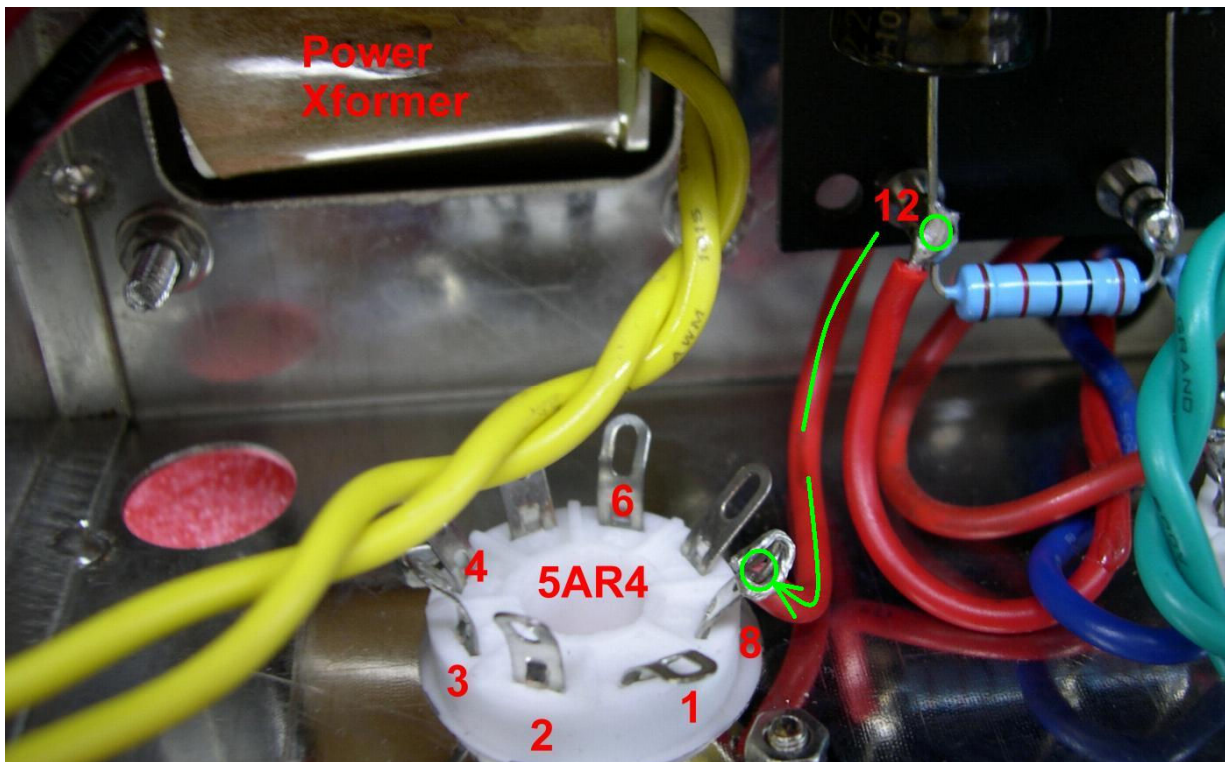

Connect one of the yellow wire from PT to Pin8 of 5AR4, and connect the other yellow wire from PT to Pin2 of 5AR4; see below:

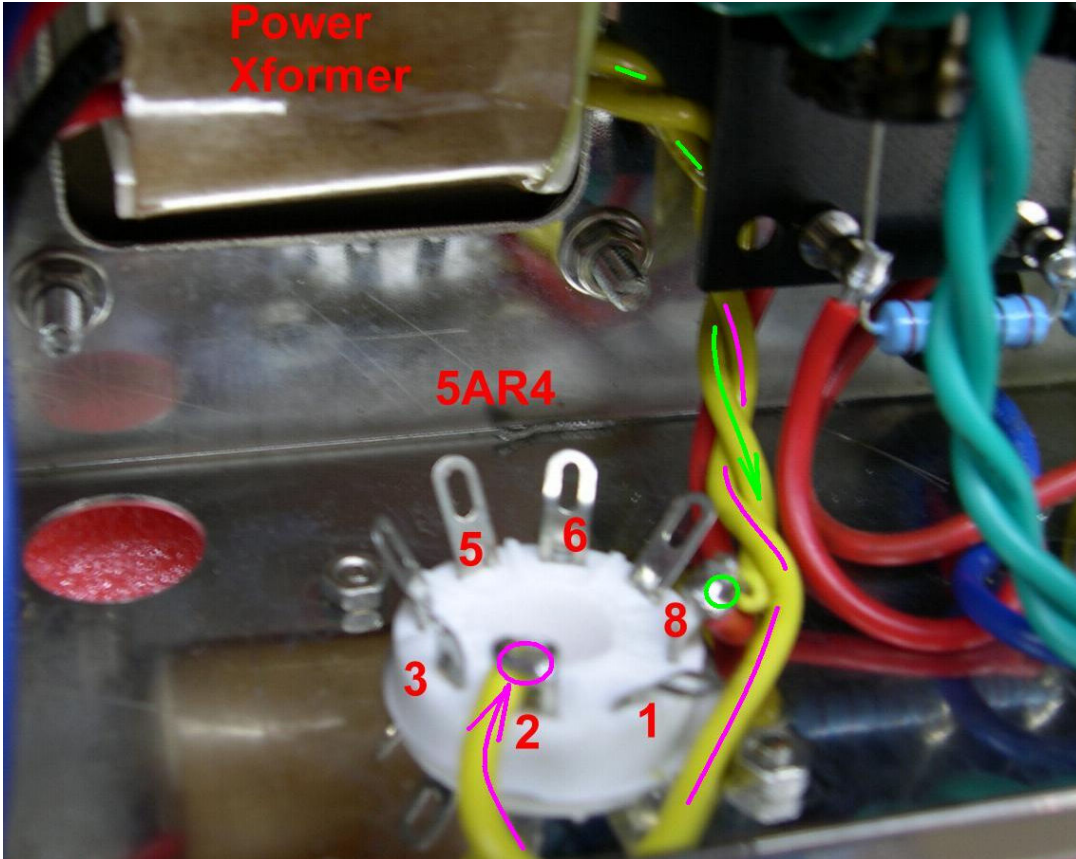

Solder one BYV26EV diode across Pin3(+) to Pin4(-) of 5AR4 as below;
and solder another BYV26EV diode across Pin5(+) to Pin6(-) of 5AR4 as below;
Connect one of the red wires from PT to Pin3 of 5AR4, and connect the other red wire from PT to Pin5 of 5AR4;

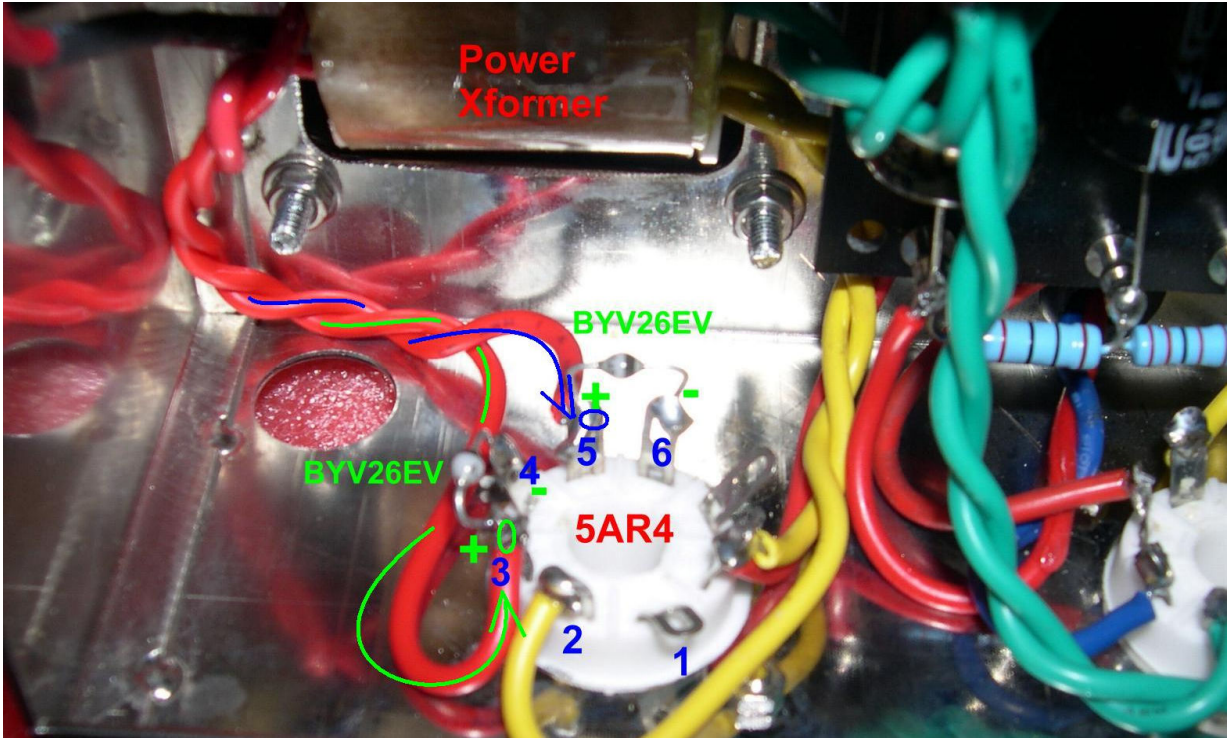

o. Put on the Power cord- see below:



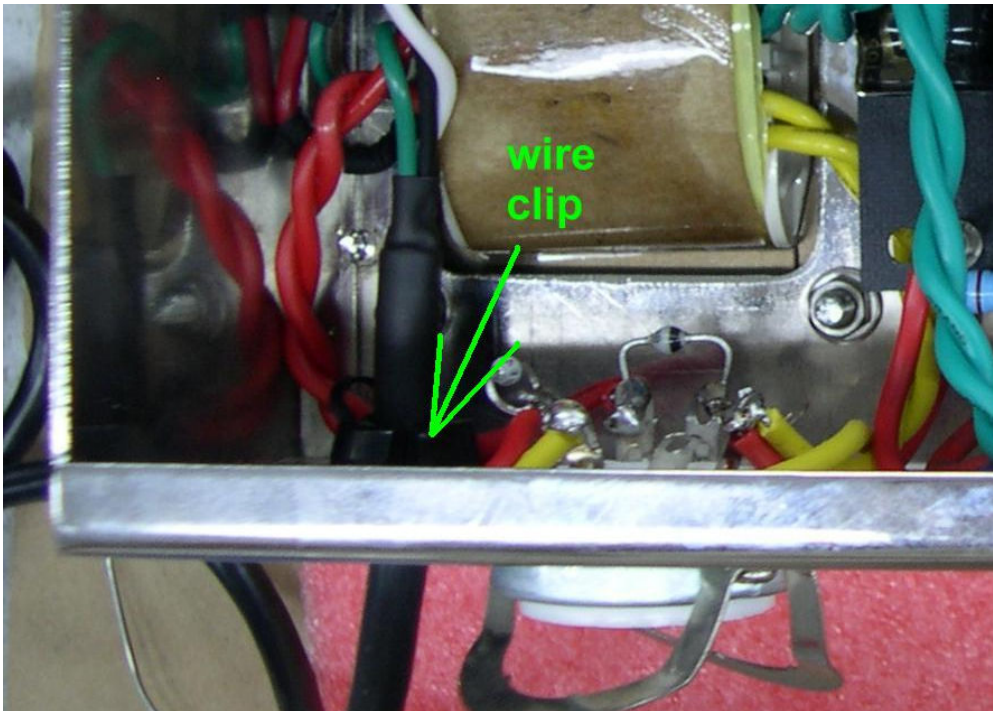
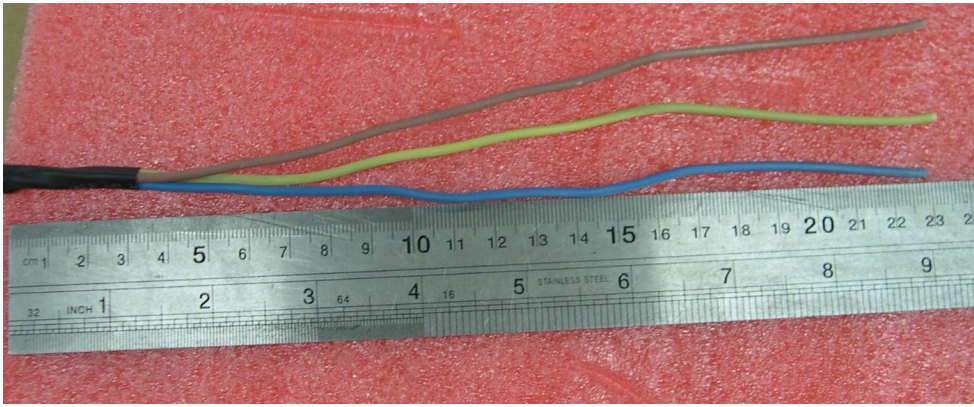

p. GND wiring- see below:

-Combine the yellow wire from Point10 on turret board with the Green/Yellow wire from PT together and solder a GND lug to the end of them; see below

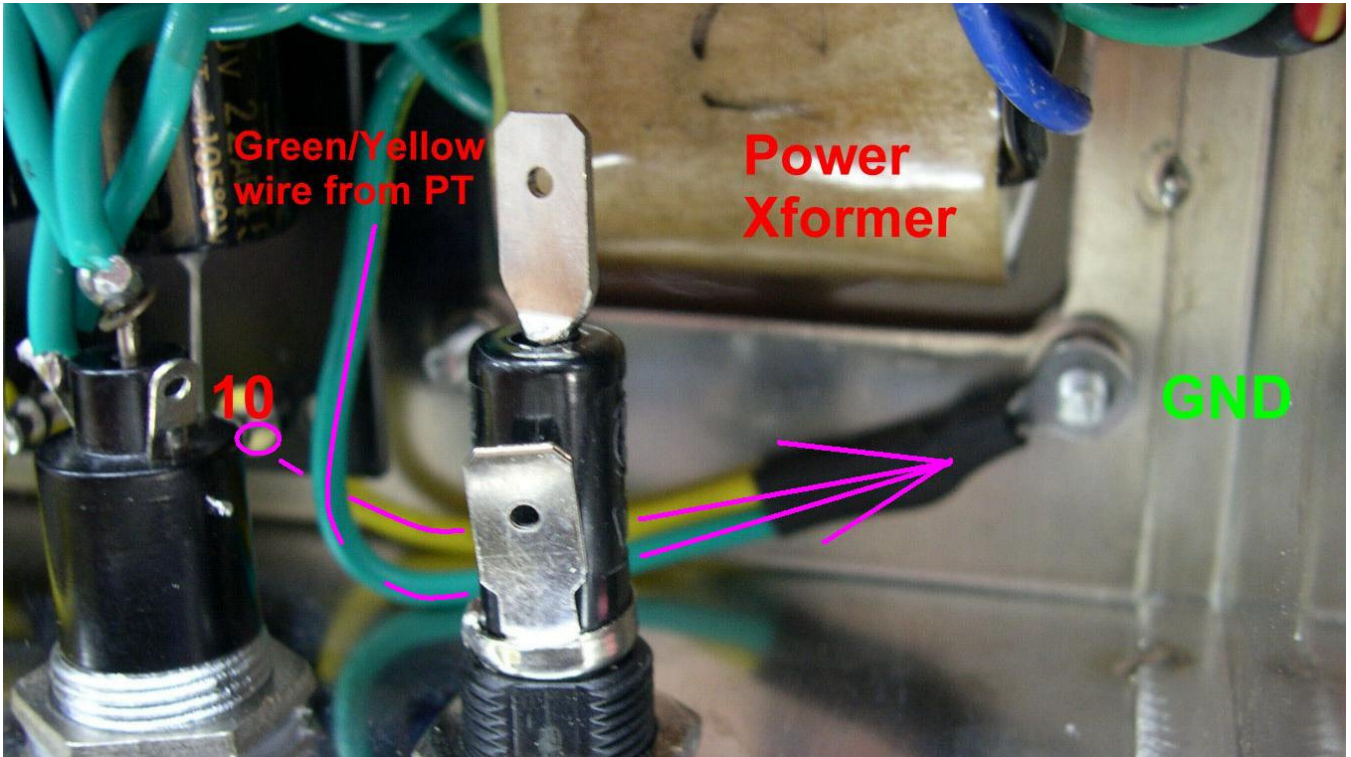

-Combine the ground wire(green) from Power cord with the Red/Yellow wire from PT together and solder a GND lug to the end of it, see below:

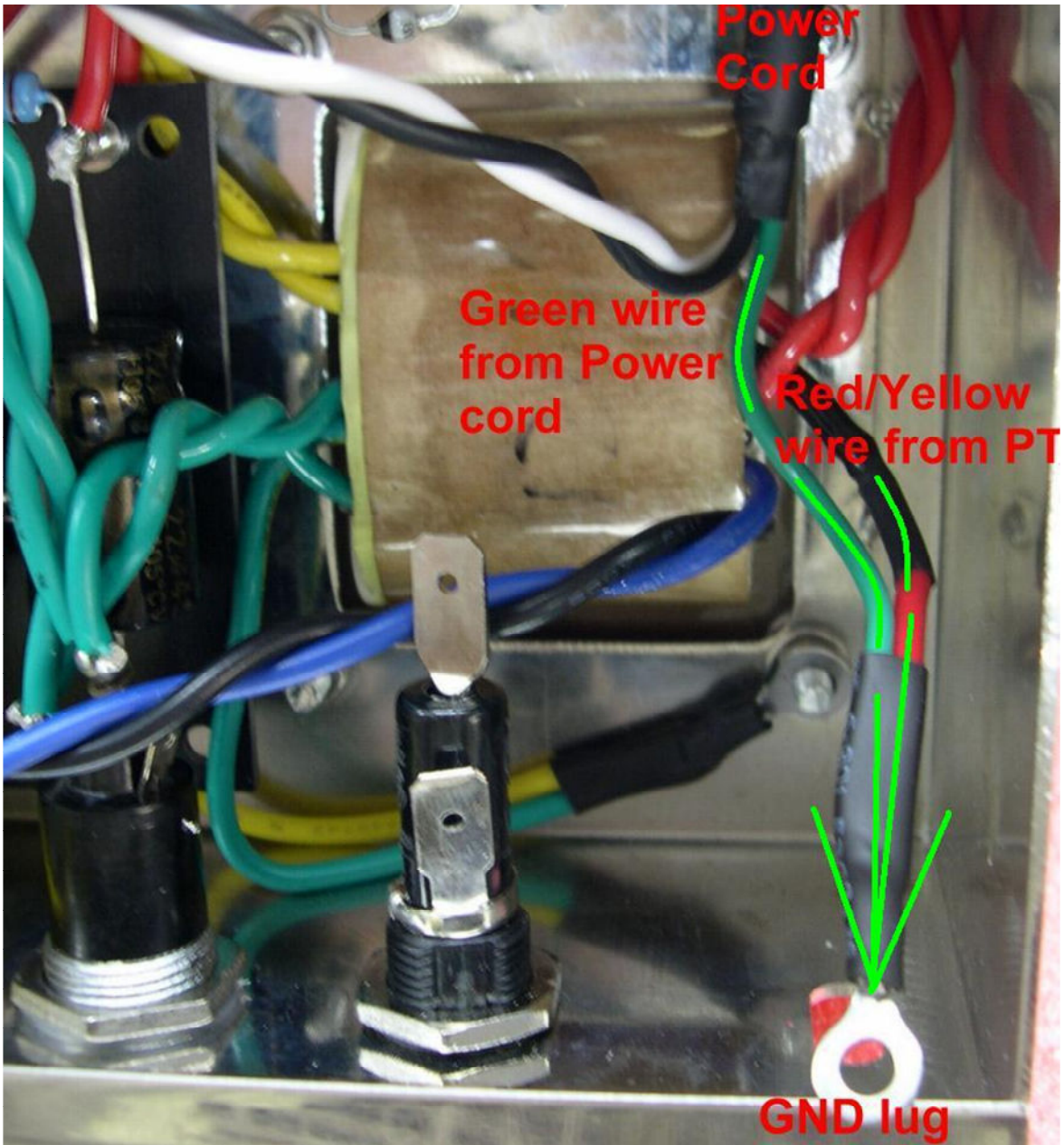

-Lock the two grounding wires onto the power transformer bolt using an M4 nut; see below

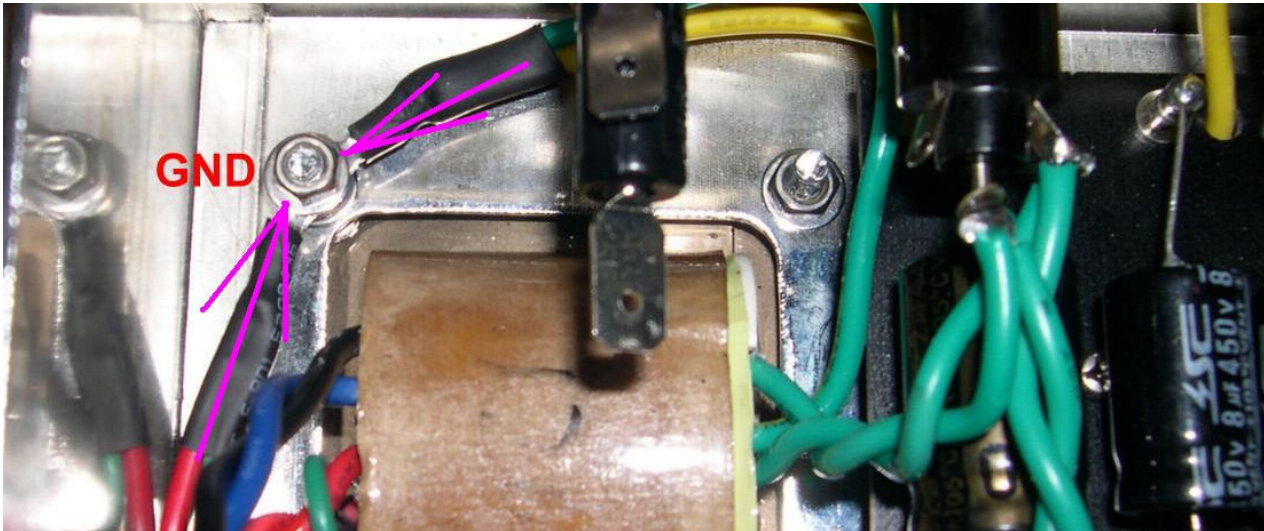

q. Power supply wirings-

- Connect the hot line(white color) from power cord to Pin4 of Potentiometer;
- Use a red wire, connect Pin5 of Potentiometer to Pin2 of Fuse Holder;

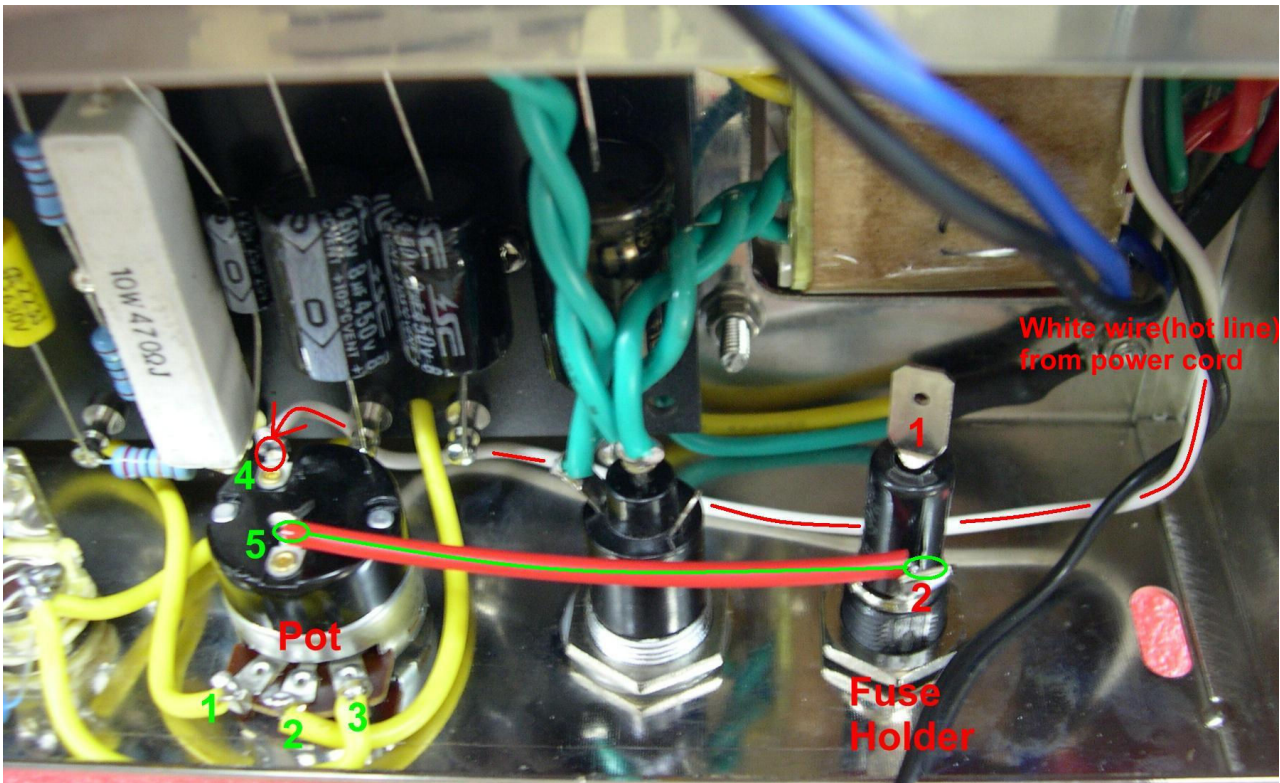

- Connect Blue wire from Power transformer to Pin1 of Fuse Holder;
- Solder the black wire(Neutral line) from power cord to the black wire from Power transformer; see below

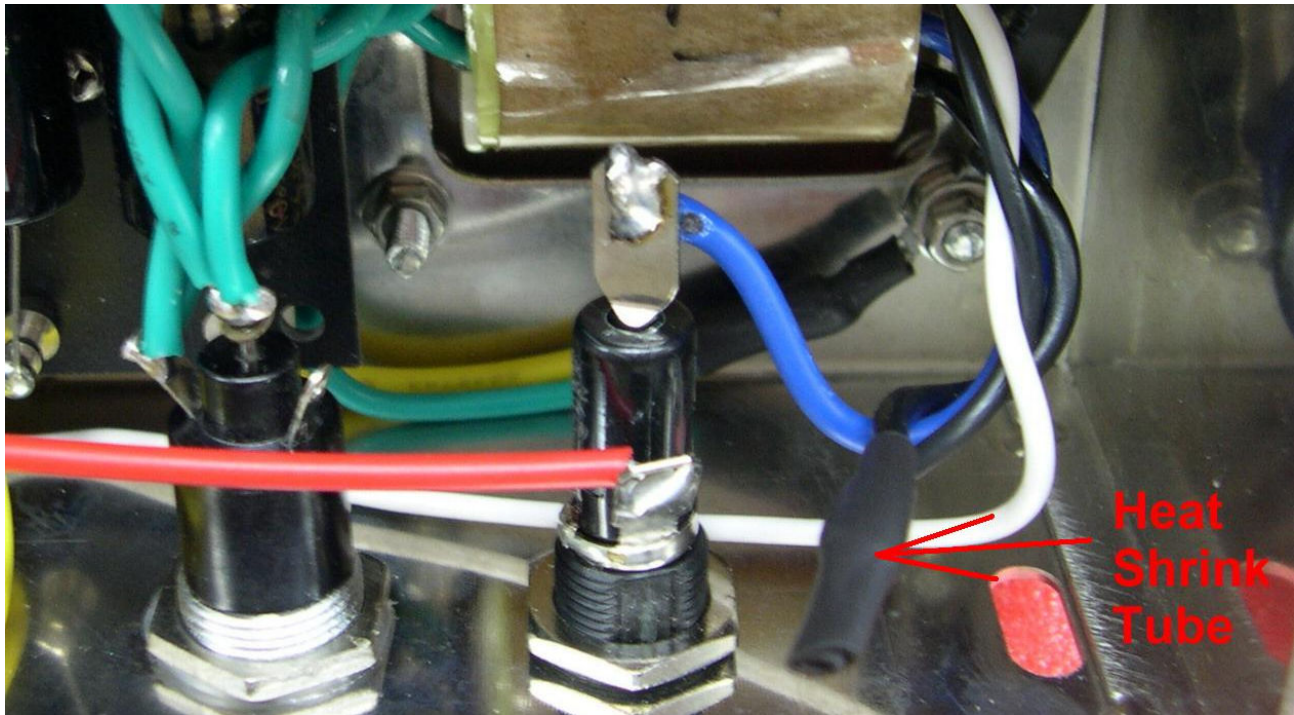
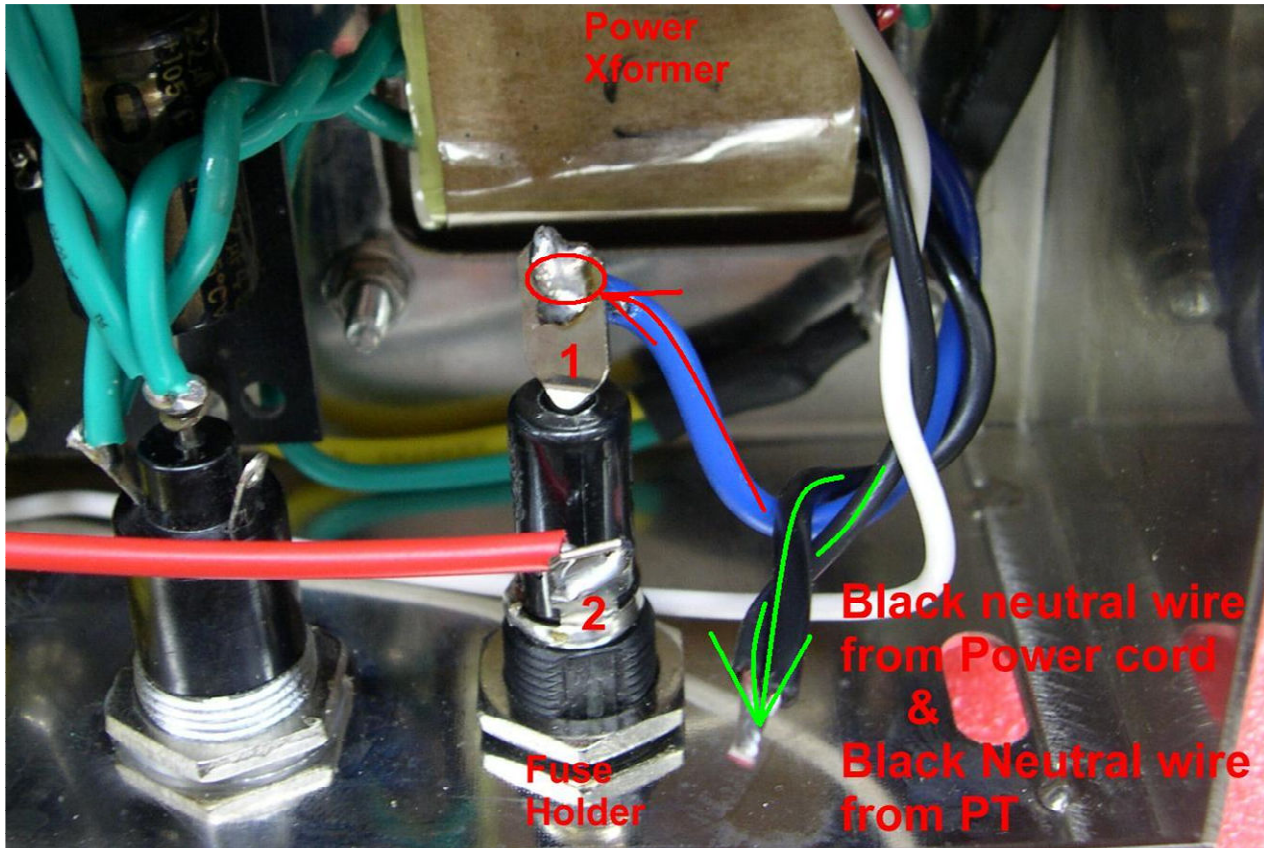

So far, we've finished all the wiring inside the chassis. Below are some quick views into the wiring. If you still have any question about the assembly, or if you are not certain about any of the procedure, contact us. We will get back to you as quickly as we can with more clear illustrations.

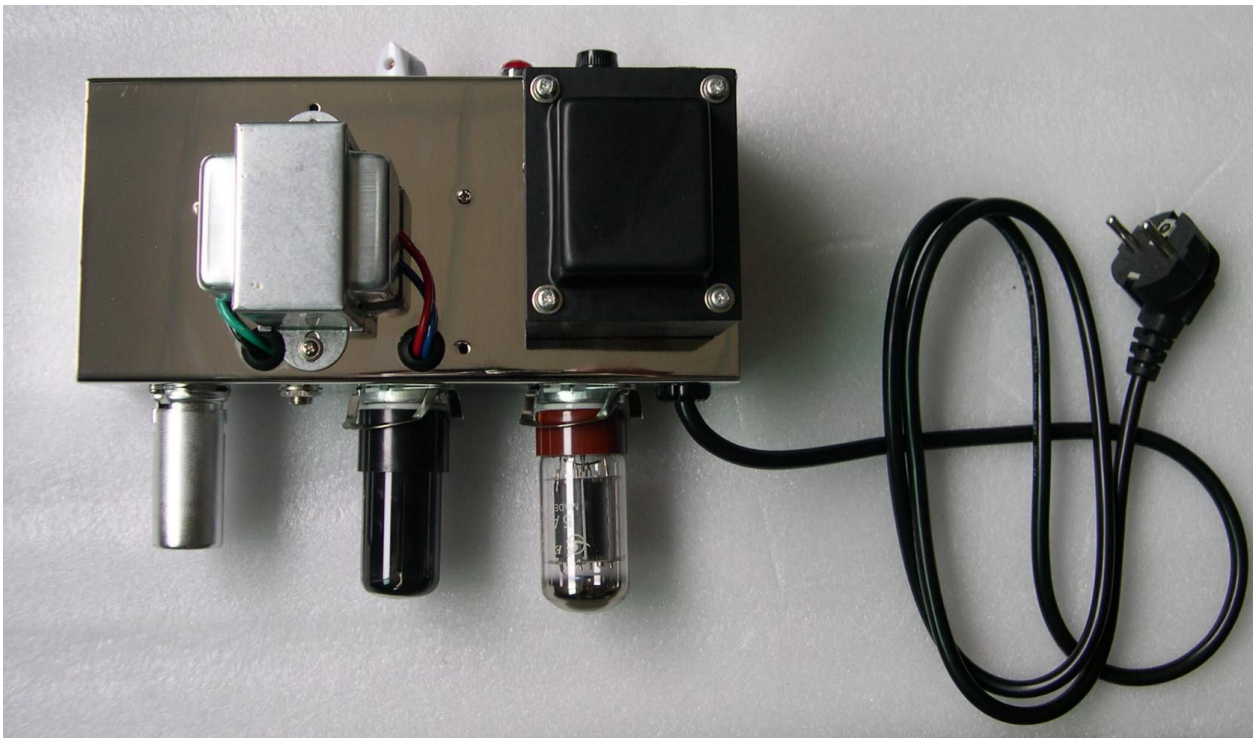
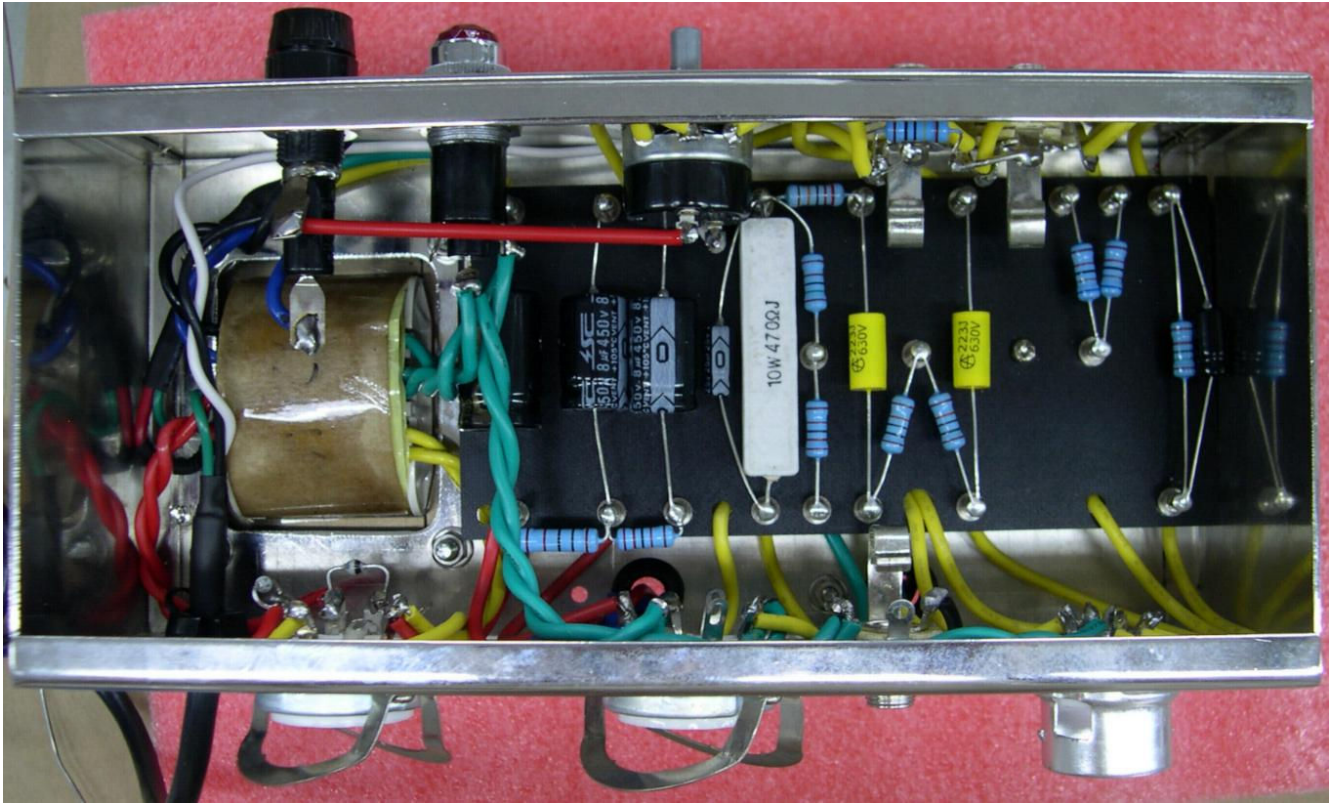

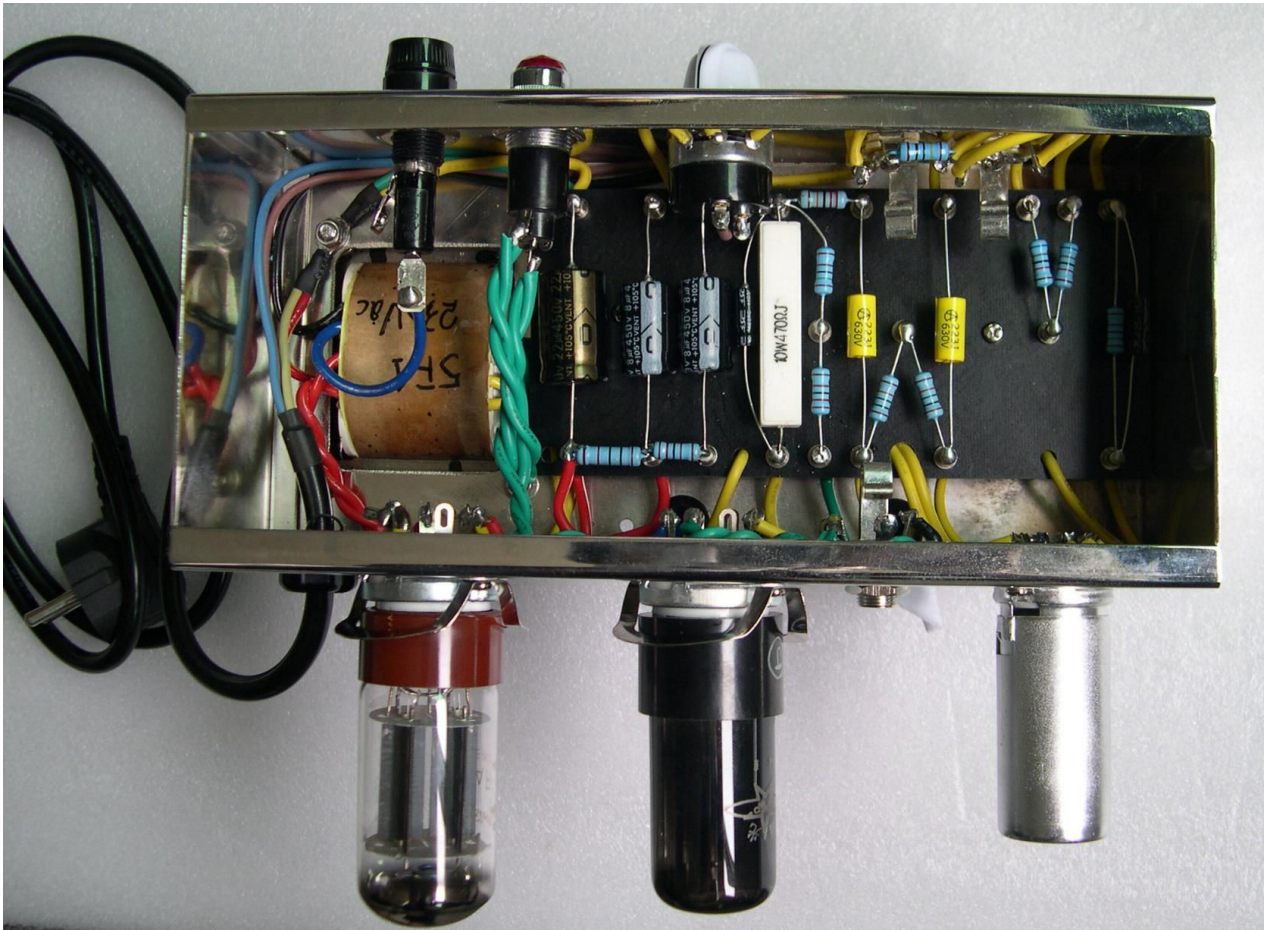

Double check all the wiring thoroughly and clean up any solder balls and wire tips that are left inside the chassis.

Put the chicken head knob on, put tubes on, run the amp on a bench test....